

LUO YAO CO., LTD

HEADER PUNCH

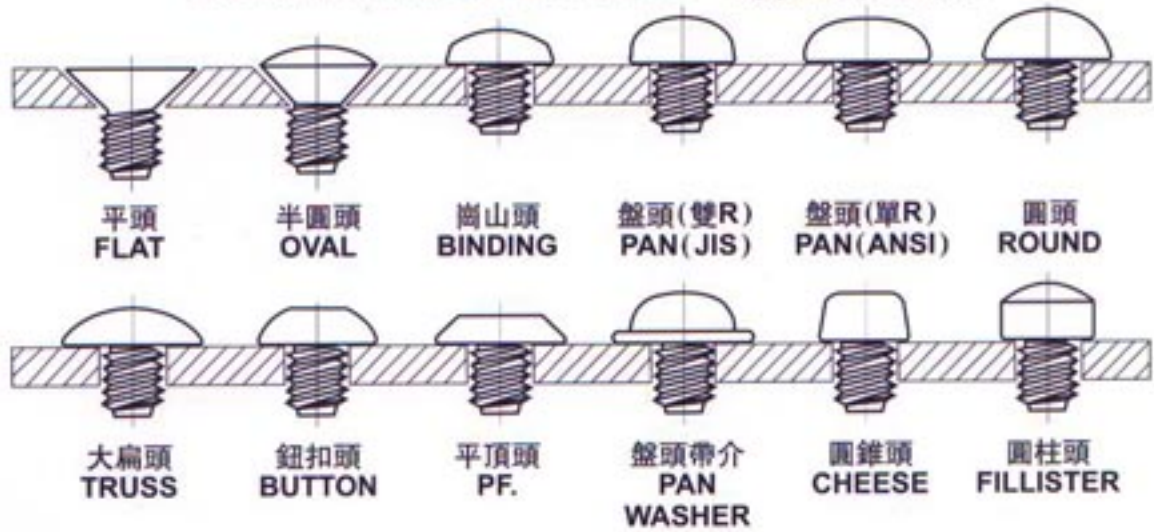

SCREW HEAD STYLES (頭型對照表)



SCREW DRIVERS (槽型對照表)

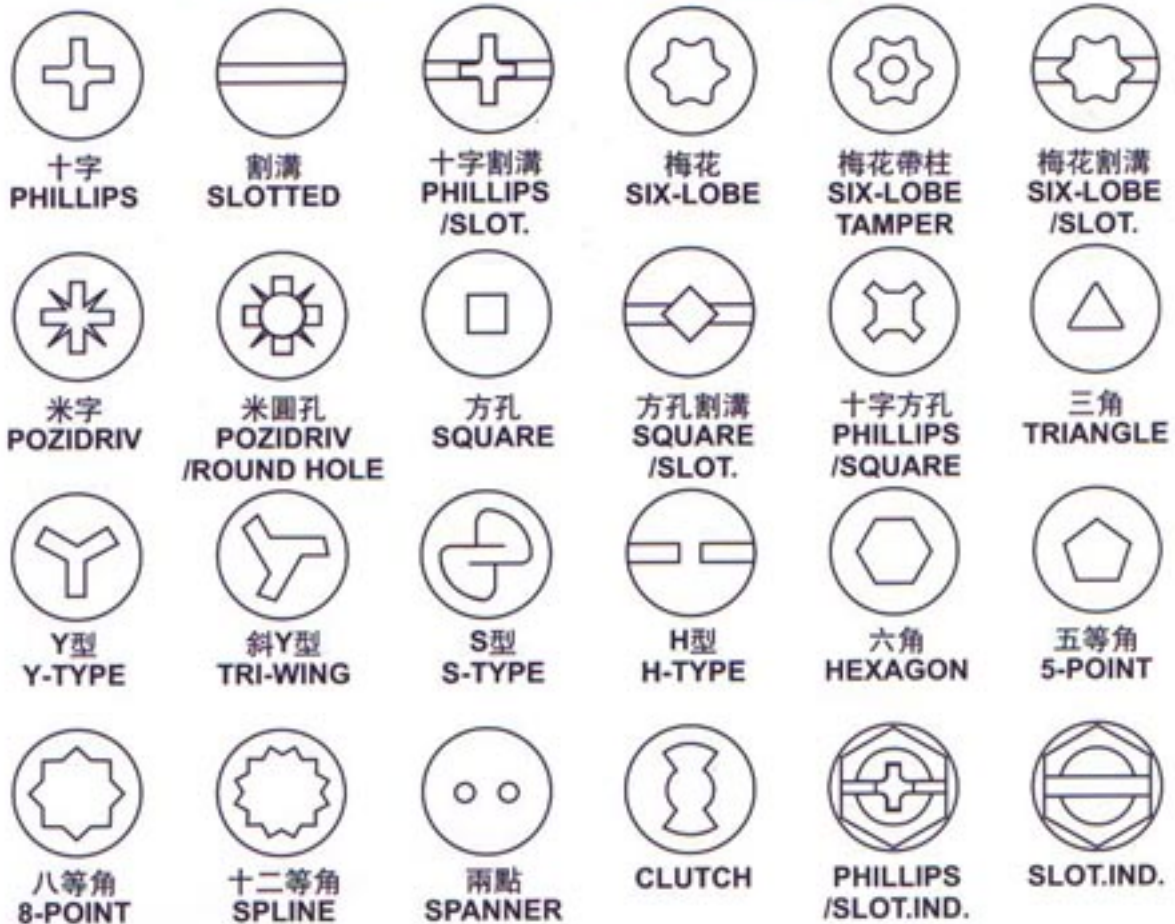

螺絲沖頭模 (SCREW SECOND PUNCH) 概述

一、PURPOSE:

Screw second punch is frequently setup with screw or bolt die. It form the screw drive with slotted, phillips, hexgon...ect.

二、STANDARD:

A: 常用國際標準規範

| | | |
|------|----------|--|
| ANSI | 美國國家標準協會 | American National Standards Institute |
| JIS | 日本工業標準 | Japanese Industrial Standards |
| DIN | 德國工業標準 | Deutsche Industrie-Normen |
| ISO | 國際標準化組織 | International Standardization Organization |
| BS | 英國國家標準 | British Standards |
| GB | 中國國家標準 | |

B: 常用頭型 (HEAD) 規格

| | |
|---------|---------|
| BINDING | 崗山頭 |
| BUTTON | 鈕扣頭 |
| BRAZIER | 鉢頭 (V頭) |
| FLAT | 平頭 |
| OVAL | 半圓頭 |
| PAN | 盤頭 |
| ROUND | 圓頭 |
| TRUSS | 大扁頭 |

C: 常用槽型 (DRIVER) 規格

| | | |
|----------|---|-----|
| PHILLIPS | ⊕ | 十字槽 |
| POZIDRIV | ⊕ | 米字槽 |
| SLOTTED | ⊖ | 一字槽 |
| TRIANGLE | △ | 三角槽 |
| SQUARE | ⊠ | 四方槽 |
| HEX. | ⊙ | 六角槽 |
| SIX-LOBE | ⊙ | 梅花槽 |
| TRI-WING | ⊙ | 斜Y槽 |

三、沖頭模外型尺寸:

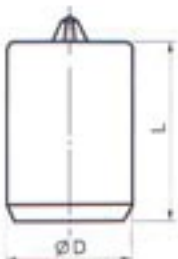

a. 外徑 ($\varnothing D$): $\varnothing 12$ 、 $\varnothing 14$ 、 $\varnothing 18$ 、 $\varnothing 23$ 、 $\varnothing 30$ mm.

b. 長度 (L): 25mm.

四、Product Code:



① Standard:

Code : Purpose

| | | |
|---|---|------|
| J | : | JIS |
| A | : | ANSI |
| D | : | DIN |
| I | : | ISO |

② Screw Using Area:

Code : Purpose

| | | |
|---|---|---------------|
| M | : | MACHINE SCREW |
| T | : | TAPPING SCREW |
| W | : | WOOD SCREW |

③ Header Type:

Code : Purpose

| | | |
|---|---|---------|
| F | : | FLAT |
| P | : | PAN |
| T | : | TRUSS |
| B | : | BINDING |
| V | : | BRAZIER |
| O | : | OVAL |
| R | : | ROUND |

④ Slotted Type:

Code : Purpose

| | | |
|-----|---|---------|
| ⊕ | : | 十字槽 |
| ⊕⊖ | : | 十字割溝復合槽 |
| ⊗ | : | 米字槽 |
| T20 | : | 梅花槽 |
| S | : | 單行道槽 |
| H | : | H型槽 |

⑤ Description

標準 公稱舉例

| | | |
|------|---|------------------|
| JIS | : | M20、M23、M26..... |
| ANSI | : | #2、#4、#6、#8..... |
| DIN | : | M20、M22、M29..... |

⑦ Notation:

代號 含義

| | | |
|------|---|----------|
| TIN | : | |
| Q1.0 | : | 槽深指定 |
| 鑽0.8 | : | 鑽孔 Ø0.8 |
| 刻G | : | 頭型上刻G |
| SUS | : | 不銹鋼螺絲用沖頭 |

⑥ Header Outer Diameter:

Ø12、Ø14、Ø18、Ø23

五. Header Marker:

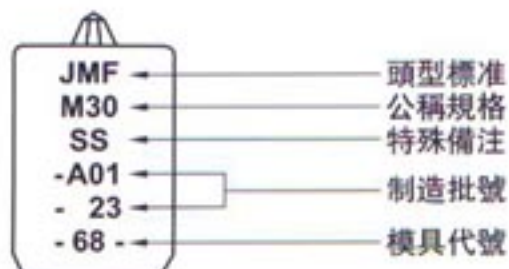

INDEX:

| | |
|---|----|
| JIS Screw Head Specification..... | 1 |
| DIN Screw Head Specification..... | 6 |
| ANSI Screw Head Specification..... | 10 |
| Screw Plug / Penetration Gage..... | 17 |
| SIX-LOBE Specification..... | 18 |
| POZI (DIN) Specification..... | 19 |
| PAN HEAD H Drive Specification..... | 22 |
| SQUARE ANSI FLAT HEAD Specification..... | 23 |
| FLAT HEAD (Hex, Six-lobe) Spectioncation..... | 24 |
| ANSI PAN, DIN 7985 SIX LOBE Specification..... | 27 |
| BOTTON HEAD (Hex, Six-lobe) Specification..... | 29 |
| PF. HEAD (Six-lobe, Phillips) Specification..... | 33 |
| HEXAGON Header Punch..... | 35 |
| THREAD ROLLING DIE..... | 41 |
| MACHINE SCREW Specification..... | 42 |
| WOOD SCREW Specification..... | 44 |
| TAPPING SCREW Specification..... | 45 |
| TAPTITE SCREW Specification..... | 47 |
| Chipboard & Drywall Screw Specification..... | 49 |
| DRILL POINT SCREW DIES Specification..... | 50 |
| TOOLING DRAWING..... | 51 |
| Cold Forged Metal Chemical List (Carbon and Stainless Steel)..... | 53 |
| PVD Titanium Coating Performance List..... | 56 |



JMP (JIS PAN HEAD MACHINE & TAPPING SCREW)

| 規格 (d) | D | | H | | R ₁ | R ₂ | a | | b | | R | M | Q | | 打字 |
|-----------|----------|------|----------|-------|----------------|----------------|----------|-------|----------|-------|------|-----|------|------|----------|
| | 基準 寸法 | 許容差 | 基準 寸法 | 許容差 | 約 | 約 | 基準 寸法 | 許容差 | 基準 寸法 | 許容差 | 最小 | 最大 | 最大 | 最小 | |
| M1 | 2 | 0 | 0.65 | | 3 | 0.3 | 0.32 | | 0.3 | | 0.1 | | | | |
| M1.2 | 2.3 | -0.3 | 0.8 | | 3.5 | 0.4 | 0.32 | +0.1 | 0.4 | +0.05 | 0.1 | | | | |
| M1.4 | 2.6 | | 0.9 | | 3.7 | 0.5 | 0.32 | | 0.5 | | 0.1 | | | | |
| M1.6 | 3 | | 1 | | 4 | 0.5 | 0.4 | | 0.55 | | 0.1 | | | | |
| M1.7 | 3.2 | | 1.1 | +0.1 | 4.2 | 0.6 | 0.4 | | 0.6 | +0.1 | 0.1 | 2.2 | 1.01 | 0.60 | JMP M2.0 |
| M2 | 3.5 | 0 | 1.3 | | 4.5 | 0.7 | 0.6 | | 0.7 | | 0.1 | 2.4 | 1.21 | 0.80 | JMP M2.3 |
| M2.2 | 4 | -0.4 | 1.5 | | 5 | 0.8 | 0.6 | | 0.8 | | 0.1 | 2.4 | 1.21 | 0.80 | JMP M2.3 |
| M2.3 | 4 | | 1.5 | | 5 | 0.8 | 0.6 | +0.15 | 0.8 | | 0.1 | 2.6 | 1.42 | 1.00 | JMP M2.6 |
| M2.5 | 4.5 | | 1.7 | | 6 | 0.9 | 0.8 | 0 | 0.9 | +0.15 | 0.1 | 2.6 | 1.42 | 1.00 | JMP M2.6 |
| M2.6 | 4.5 | | 1.7 | | 6 | 0.9 | 0.8 | | 0.9 | | 0.1 | 3.5 | 1.43 | 0.86 | JMP M3.0 |
| M3 | 5.5 | 0 | 2 | | 7 | 1.1 | 0.8 | | 1.1 | | 0.1 | 3.8 | 1.73 | 1.15 | JMP M3.5 |
| M3.5 | 6 | -0.5 | 2.3 | | 8 | 1.3 | 1 | | 1.25 | +0.2 | 0.2 | 4.1 | 2.03 | 1.45 | JMP M4.0 |
| M4 | 7 | | 2.6 | +0.15 | 9 | 1.5 | 1 | | 1.4 | | 0.2 | 4.5 | 2.43 | 1.84 | JMP M4.5 |
| M4.5 | 8 | 0 | 2.9 | | 11 | 1.7 | 1 | | 1.6 | +0.25 | 0.2 | 4.8 | 2.73 | 2.14 | JMP M5.0 |
| M5 | 9 | -0.6 | 3.3 | | 12 | 1.9 | 1.2 | +0.2 | 1.8 | +0.3 | 0.25 | 6.2 | 2.86 | 2.26 | JMP M6.0 |
| M6 | 10.5 | 0 | 3.9 | +0.2 | 14 | 2.3 | 1.2 | 0 | 2.1 | | 0.4 | 7.7 | 4.36 | 3.73 | JMP M8.0 |
| M8 | 14 | 0 | 5.2 | | 18 | 3 | 1.6 | | 2.8 | +0.5 | | | | | |

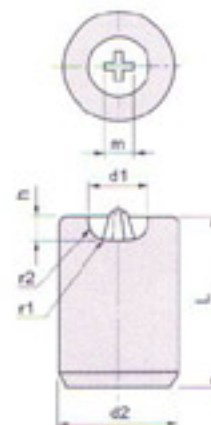

JMT (JIS TRUSS HEAD MACHINE & TAPPING SCREW)

| 規格 (d) | D | | H | | R ₁ | a | b | | R | M | Q | | 打字 | |
|-----------|----------|------|----------|-------|----------------|----------|-------|----------|-------|------|-----|------|------|-----------------|
| | 基準 寸法 | 許容差 | 基準 寸法 | 許容差 | 約 | 基準 寸法 | 許容差 | 基準 寸法 | 許容差 | 最小 | 最大 | 最大 | | 最小 |
| M2 | 4.5 | | 1.2 | | 3 | 0.6 | | 0.6 | | 0.1 | 2.2 | 1.01 | 0.65 | JMT M2.0 |
| M2.2 | 5 | | 1.3 | | 3.2 | 0.6 | | 0.65 | | 0.1 | 2.3 | 1.11 | 0.75 | JMT M2.2 |
| M2.3 | 5.2 | 0 | 1.4 | +0.1 | 3.4 | 0.6 | | 0.7 | +0.1 | 0.1 | 2.4 | 1.21 | 0.85 | JMT M2.3 |
| M2.5 | 5.7 | -0.4 | 1.5 | | 3.7 | 0.8 | | 0.75 | | 0.1 | 2.5 | 1.32 | 0.95 | JMT M2.5 |
| M2.6 | 5.9 | | 1.6 | | 3.9 | 0.8 | | 0.8 | | 0.1 | 2.6 | 1.42 | 1.05 | JMT M2.6 |
| *M3 | 6.9 | | 1.9 | | 4.6 | 0.8 | +0.15 | 0.95 | | 0.1 | 2.9 | 1.72 | 1.34 | JMT M3.0 (PH#1) |
| M3 | 6.9 | 0 | 1.9 | | 4.6 | 0.8 | 0 | 0.95 | ±0.15 | 0.1 | 3.6 | 1.55 | 1.05 | JMT M3.0 |
| M3.5 | 8.1 | -0.5 | 2.2 | +0.15 | 5.4 | 1 | | 1.1 | | 0.1 | 3.9 | 1.83 | 1.30 | JMT M3.5 |
| M4 | 9.4 | | 2.5 | | 6.1 | 1 | | 1.25 | +0.2 | 0.2 | 4.2 | 2.13 | 1.60 | JMT M4.0 |
| M4.5 | 10.6 | 0 | 2.8 | | 6.9 | 1 | | 1.4 | | 0.2 | 4.6 | 2.53 | 1.99 | JMT M4.5 |
| M5 | 11.8 | -0.6 | 3.1 | | 7.7 | 1.2 | +0.2 | 1.6 | ±0.25 | 0.2 | 4.9 | 2.83 | 2.29 | JMT M5.0 |
| M6 | 14 | 0 | 3.7 | +0.2 | 9.1 | 1.2 | 0 | 1.9 | ±0.3 | 0.25 | 6.2 | 2.86 | 2.31 | JMT M6.0 |
| M8 | 17.8 | 0 | 4.8 | | 11.7 | 1.6 | | 2.4 | ±0.4 | 0.4 | 7.7 | 4.36 | 3.78 | JMT M8.0 |

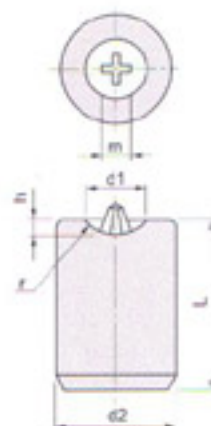

JMB (JIS BINDING HEAD MACHINE & TAPPING SCREW)

| 規格 (d) | D | | H | | K | | H+K | | a | | b | | R | | M | | Q | | 打字 |
|-----------|------|------|------|------|-------|-----|------|-------|------|-------|------|-------|------|-----|------|------|----|----|----------|
| | 基本寸法 | 許容差 | 約 | 許容差 | 基本寸法 | 許容差 | 基本寸法 | 許容差 | 基本寸法 | 許容差 | 基本寸法 | 許容差 | 最小 | 最大 | 最大 | 最小 | 最大 | 最小 | |
| M2 | 4.3 | | 0.85 | 0.35 | | | 1.2 | | 0.6 | | 0.65 | | 0.1 | 2.2 | 1.01 | 0.65 | | | JMB M2.0 |
| M2.2 | 4.7 | | 0.9 | 0.4 | | | 1.3 | | 0.6 | | 0.7 | | 0.1 | 2.3 | 1.11 | 0.75 | | | JMB M2.2 |
| M2.3 | 4.9 | 0 | 1 | 0.4 | +0.1 | | 1.4 | +0.15 | 0.6 | | 0.7 | +0.1 | 0.1 | 2.4 | 1.21 | 0.85 | | | JMB M2.3 |
| M2.5 | 5.3 | -0.4 | 1 | 0.5 | | | 1.5 | | 0.8 | | 0.8 | | 0.1 | 2.5 | 1.32 | 0.95 | | | JMB M2.5 |
| M2.6 | 5.5 | | 1.1 | 0.5 | | | 1.6 | | 0.8 | +0.15 | 0.85 | | 0.1 | 2.6 | 1.42 | 1.05 | | | JMB M2.6 |
| M3 | 6.3 | | 1.3 | 0.6 | | | 1.9 | | 0.8 | | 1 | +0.15 | 0.1 | 3.6 | 1.53 | 1.01 | | | JMB M3.0 |
| M3.5 | 7.3 | 0 | 1.5 | 0.7 | | | 2.2 | | 1 | | 1.15 | +0.2 | 0.1 | 3.9 | 1.83 | 1.30 | | | JMB M3.5 |
| M4 | 8.3 | -0.5 | 1.7 | 0.8 | | | 2.5 | | 1 | | 1.3 | | 0.2 | 4.2 | 2.13 | 1.60 | | | JMB M4.0 |
| M4.5 | 9.3 | | 1.9 | 0.9 | +0.15 | | 2.8 | +0.2 | 1 | | 1.5 | +0.25 | 0.2 | 4.6 | 2.53 | 1.99 | | | JMB M4.5 |
| M5 | 10.3 | -0.6 | 2.1 | 1 | | | 3.1 | | 1.2 | | 1.7 | | 0.2 | 4.9 | 2.83 | 2.29 | | | JMB M5.0 |
| M6 | 12.4 | 0 | 2.4 | 1.3 | | | 3.7 | | 1.2 | +0.2 | 2 | +0.3 | 0.25 | 6.2 | 2.86 | 2.31 | | | JMB M6.0 |
| M8 | 16.4 | 0 | 3.1 | 1.7 | +0.2 | | 4.8 | +0.3 | 1.6 | | 2.8 | +0.5 | 0.4 | 7.7 | 4.36 | 3.78 | | | JMB M8.0 |

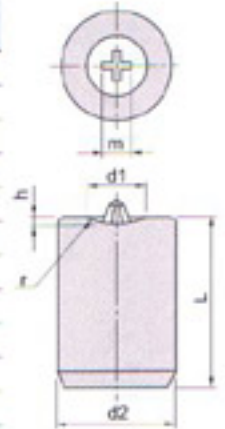

IND (JIS B1123)

| 規格 | 3 | 3.5 | 4 | 4.5 | 5 | 6 | 8 | | |
|-------|--------|----------|--------|----------|--------|--------|--------|-------|------|
| B | 基本寸法 | 5 | 5.5 | 7 | 8 | 10 | 12 | | |
| | 許容差 | | | 0 | -0.2 | | 0 | -0.25 | |
| C | 最小 | 5.5 | 6.05 | 7.7 | 8.7 | 10.9 | 13.1 | | |
| | 許容差 | | | +0.1 | | | +0.15 | | |
| H | 基本寸法 | 1.6 | 2.3 | 2.5 | 2.7 | 3 | 3.5 | | |
| | 許容差 | | | +0.1 | | | +0.15 | | |
| r | 最大 | 0.4 | | 0.5 | | 0.6 | 0.7 | | |
| 十字穴 | M | 最大 | 2.5 | 3.5 | 4 | 4.2 | 4.4 | 6.2 | 7.2 |
| | Q | 最大 | 1.32 | 1.43 | 1.93 | 2.13 | 2.33 | 2.86 | 3.86 |
| | Q | 最小 | 0.95 | 0.91 | 1.40 | 1.59 | 1.80 | 2.30 | 3.20 |
| 十字穴番號 | 1 | | 2 | | | 3 | | | |
| 打字 | IND M3 | IND M3.5 | IND M4 | IND M4.5 | IND M5 | IND M6 | IND M8 | | |

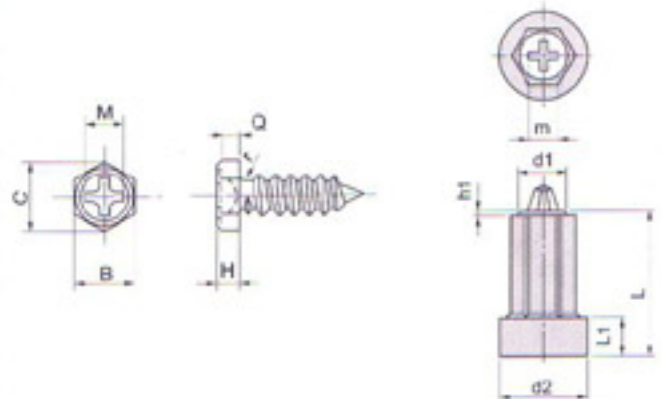

SP IND (JIS B1187)

| 規格 | 粗牙 | M 4X0.7 | M 5X0.8 | M 6 | M 8 |
|-------|-------|--------------------------------|--------------------------------|---------------------------------|----------------------------------|
| | 細牙 | — | — | — | M 8X1 |
| H | | 2.8+0.1 | 3.5+0.15 | 4+0.15 | 5.5+0.15 |
| B | | 7 ⁰ _{-0.2} | 8 ⁰ _{-0.2} | 10 ⁰ _{-0.2} | 12 ⁰ _{-0.25} |
| C(最小) | | 7.74 | 8.87 | 11.05 | 13.25 |
| h(最小) | | 1.9 | 2.3 | 2.7 | 3.7 |
| 十字穴 | 十字穴番號 | 2 | 2 | 3 | 3 |
| | M(最大) | 4.0 | 4.8 | 6.2 | 7.2 |
| | Q | 1.93~1.40 | 2.73~2.19 | 2.86~2.31 | 3.86~3.24 |
| 打字 | | SP IND M 4 | SP IND M 5 | SP IND M 6 | SP IND M 8 |

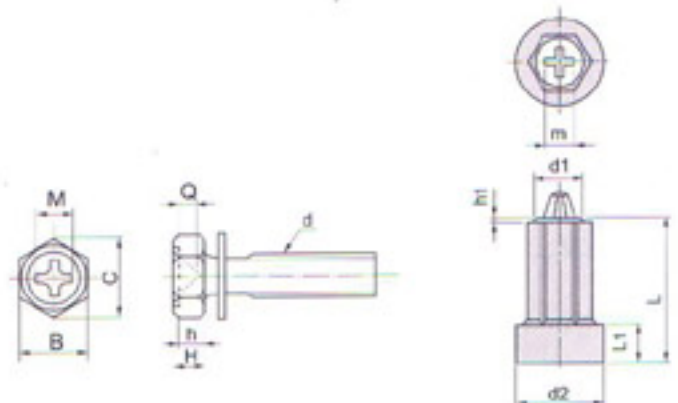

JMF (JIS FLAT HEAD MACHINE & TAPPING SCREW)

| 規格 (d) | D | | H | | c | | a | | b | | R | M | | Q | | 打 字 |
|-----------|------|-----------|------|-----------|------|------|------------|------|-------|------|-----|------|------|----|--|----------|
| | 基本寸法 | 許容差 | 基本寸法 | 許容差 | 約 | 基本寸法 | 許容差 | 約 | 基本寸法 | 許容差 | 約 | 最大 | 最大 | 最小 | | |
| M1 | 2 | | 0.6 | | 0.1 | 0.32 | | 0.25 | | 0.1 | | | | | | |
| M1.2 | 2.4 | 0 -0.3 | 0.7 | 0 -0.1 | 0.1 | 0.32 | +0.1 0 | 0.3 | | 0.12 | | | | | | |
| M1.4 | 2.8 | | 0.85 | | 0.15 | 0.32 | | 0.3 | +0.05 | 0.14 | | | | | | |
| M1.6 | 3.2 | | 0.95 | | 0.15 | 0.4 | | 0.35 | | 0.16 | | | | | | |
| M1.7 | 3.4 | | 1 | | 0.15 | 0.4 | | 0.4 | | 0.17 | | | | | | |
| M2 | 4 | | 1.2 | | 0.2 | 0.6 | | 0.5 | | 0.2 | 2.2 | 1.01 | 0.65 | | | JMF M2.0 |
| M2.2 | 4.4 | 0 -0.4 | 1.3 | 0 -0.2 | 0.2 | 0.6 | | 0.5 | | 0.22 | 2.4 | 1.21 | 0.85 | | | JMF M2.2 |
| M2.3 | 4.6 | | 1.35 | | 0.2 | 0.6 | | 0.5 | +0.1 | 0.23 | 2.4 | 1.21 | 0.85 | | | JMF M2.3 |
| M2.5 | 5 | | 1.45 | | 0.2 | 0.8 | +0.15 0 | 0.6 | | 0.25 | 2.6 | 1.42 | 1.05 | | | JMF M2.5 |
| M2.6 | 5.2 | | 1.5 | | 0.2 | 0.8 | | 0.6 | | 0.26 | 2.6 | 1.42 | 1.05 | | | JMF M2.6 |
| M3 | 6 | | 1.75 | | 0.25 | 0.8 | | 0.7 | | 0.3 | 3.5 | 1.43 | 0.91 | | | JMF M3.0 |
| M3.5 | 7 | 0 -0.5 | 2 | 0 -0.3 | 0.25 | 1 | | 0.8 | +0.15 | 0.35 | 4.0 | 1.93 | 1.40 | | | JMF M3.5 |
| M4 | 8 | | 2.3 | | 0.3 | 1 | | 0.9 | | 0.4 | 4.4 | 2.33 | 1.79 | | | JMF M4.0 |
| M4.5 | 9 | 0 -0.6 | 2.55 | 0 -0.3 | 0.3 | 1 | | 1 | +0.2 | 0.45 | 4.8 | 2.73 | 2.19 | | | JMF M4.5 |
| M5 | 10 | | 2.8 | | 0.3 | 1.2 | | 1.1 | | 0.5 | 5.0 | 2.93 | 2.38 | | | JMF M5.0 |
| M6 | 12 | 0 -0.7 | 3.4 | 0 -0.4 | 0.4 | 1.2 | +0.2 0 | 1.4 | +0.25 | 0.6 | 6.6 | 3.26 | 2.70 | | | JMF M6.0 |
| M8 | 16 | 0 -0.8 | 4.4 | 0 -0.4 | 0.4 | 1.6 | | 1.8 | +0.3 | 0.8 | 8.3 | 4.96 | 4.36 | | | JMF M8.0 |

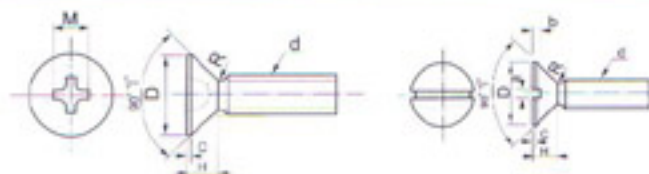

JMO (JIS OVAL HEAD MACHINE & TAPPING SCREW)

| 規格 (d) | D | | H | | c | | k | | H+k | | a | | b | | R | M | | Q | | 打 字 |
|-----------|------|-----------|------|-----------|------|------|------|-----------|------|-----------|------|-------|------|-----|------|------|----|---|--|----------|
| | 基本寸法 | 許容差 | 基本寸法 | 許容差 | 約 | 約 | 基本寸法 | 許容差 | 約 | 約 | 基本寸法 | 許容差 | 約 | 約 | 最大 | 最大 | 最小 | | | |
| M1 | 2 | | 0.6 | | 0.1 | 0.2 | 0.8 | | 0.2 | 0.32 | | 0.35 | | 0.1 | | | | | | |
| M1.2 | 2.4 | 0 -0.3 | 0.7 | 0 -0.1 | 0.1 | 0.3 | 1 | | 0.32 | +0.1 0 | 0.45 | | 0.12 | | | | | | | |
| M1.4 | 2.8 | | 0.85 | | 0.15 | 0.3 | 1.15 | | 0.32 | | 0.5 | +0.1 | 0.14 | | | | | | | |
| M1.6 | 3.2 | | 0.95 | | 0.15 | 0.35 | 1.3 | 0 -0.3 | 0.4 | | 0.55 | | 0.16 | | | | | | | |
| M1.7 | 3.4 | | 1 | | 0.15 | 0.4 | 1.4 | | 0.4 | | 0.6 | | 0.17 | | | | | | | |
| M2 | 4 | | 1.2 | | 0.2 | 0.4 | 1.6 | | 0.6 | | 0.7 | | 0.2 | 2.4 | 1.21 | 0.85 | | | | JMO M2.0 |
| M2.2 | 4.4 | 0 -0.4 | 1.3 | 0 -0.2 | 0.2 | 0.5 | 1.8 | | 0.6 | | 0.8 | | 0.22 | 2.7 | 1.52 | 1.14 | | | | JMO M2.2 |
| M2.3 | 4.6 | | 1.35 | | 0.2 | 0.5 | 1.85 | 0 -0.4 | 0.6 | +0.15 | 0.8 | | 0.23 | 2.7 | 1.52 | 1.14 | | | | JMO M2.3 |
| M2.5 | 5 | | 1.45 | | 0.2 | 0.55 | 2 | | 0.8 | | 0.9 | | 0.25 | 2.9 | 1.72 | 1.34 | | | | JMO M2.5 |
| M2.6 | 5.2 | | 1.5 | | 0.2 | 0.6 | 2.1 | | 0.8 | | 0.9 | | 0.26 | 2.9 | 1.72 | 1.34 | | | | JMO M2.6 |
| M3 | 6 | | 1.75 | | 0.25 | 0.7 | 2.45 | | 0.8 | | 1.1 | +0.2 | 0.3 | 3.7 | 1.53 | 1.11 | | | | JMO M3.0 |
| M3.5 | 7 | 0 -0.5 | 2 | 0 -0.3 | 0.25 | 0.8 | 2.8 | | 1 | | 1.2 | | 0.35 | 4.2 | 2.13 | 1.60 | | | | JMO M3.5 |
| M4 | 8 | | 2.3 | | 0.3 | 0.9 | 3.2 | 0 -0.5 | 1 | | 1.4 | +0.25 | 0.4 | 4.6 | 2.53 | 1.99 | | | | JMO M4.0 |
| M4.5 | 9 | 0 -0.6 | 2.55 | 0 -0.3 | 0.3 | 1 | 3.55 | | 1 | | 1.5 | +0.3 | 0.45 | 5.0 | 2.93 | 2.38 | | | | JMO M4.5 |
| M5 | 10 | | 2.8 | | 0.3 | 1.2 | 4 | | 1.2 | | 1.7 | | 0.5 | 5.2 | 3.13 | 2.58 | | | | JMO M5.0 |
| M6 | 12 | 0 -0.7 | 3.4 | 0 -0.4 | 0.4 | 1.4 | 4.8 | 0 -0.6 | 1.2 | +0.2 0 | 2.1 | +0.4 | 0.6 | 6.8 | 3.46 | 2.90 | | | | JMO M6.0 |
| M8 | 16 | 0 -0.8 | 4.4 | 0 -0.4 | 0.4 | 1.8 | 6.2 | | 1.6 | | 2.7 | +0.5 | 0.8 | 8.5 | 5.16 | 4.56 | | | | JMO M8.0 |

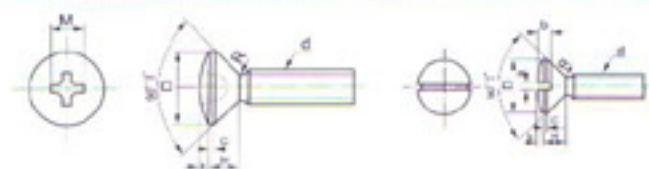
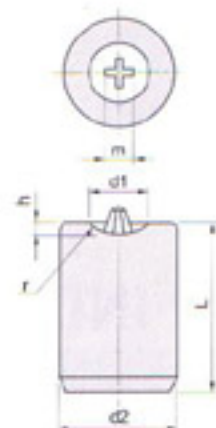

JMR (JIS ROUND HEAD MACHINE & TAPPING SCREW)

| 規格 (d) | D | | H | | R _c | R _e | a | | b | | R | M | Q | 打字 | |
|-----------|------|------|-----|-------|----------------|----------------|------|-------|------|-------|------|-----|------|------|----------|
| | 公差 | 許容差 | 公差 | 許容差 | 約 | 約 | 公差 | 許容差 | 公差 | 許容差 | 最小 | 最大 | 最大 | | 最小 |
| M1 | 2 | 0 | 0.8 | | 1.2 | 0.7 | 0.32 | | 0.45 | | 0.1 | | | | |
| M1.2 | 2.3 | -0.3 | 0.9 | | 1.4 | 0.8 | 0.32 | +0.1 | 0.5 | | 0.1 | | | | |
| M1.4 | 2.6 | | 1 | | 1.6 | 0.9 | 0.32 | | 0.6 | +0.1 | 0.1 | | | | |
| M1.6 | 3 | | 1.1 | | 1.8 | 1 | 0.4 | | 0.65 | | 0.1 | | | | |
| M1.7 | 3.2 | | 1.2 | | 1.9 | 1.1 | 0.4 | | 0.7 | | 0.1 | | | | |
| M2 | 3.5 | 0 | 1.3 | ±0.1 | 2.1 | 1.2 | 0.6 | | 0.8 | | 0.1 | 2.1 | 0.91 | 0.50 | JMR M2.0 |
| M2.2 | 4 | -0.4 | 1.5 | | 2.4 | 1.3 | 0.6 | | 0.9 | | 0.1 | 2.3 | 1.11 | 0.70 | JMR M2.3 |
| M2.3 | 4 | | 1.5 | | 2.4 | 1.3 | 0.6 | | 0.9 | | 0.1 | 2.3 | 1.11 | 0.70 | JMR M2.3 |
| M2.5 | 4.5 | | 1.7 | | 2.7 | 1.5 | 0.8 | +0.15 | 1 | +0.15 | 0.1 | 2.5 | 1.32 | 0.90 | JMR M2.6 |
| M2.6 | 4.5 | | 1.7 | | 2.7 | 1.5 | 0.8 | 0 | 1 | | 0.1 | 2.5 | 1.32 | 0.90 | JMR M2.6 |
| M3 | 5.5 | | 2 | | 3.3 | 1.8 | 0.8 | | 1.2 | +0.2 | 0.1 | 3.4 | 1.33 | 0.76 | JMR M3.0 |
| M3.5 | 6 | 0 | 2.3 | | 3.6 | 2 | 1 | | 1.4 | | 0.1 | 3.7 | 1.63 | 1.06 | JMR M3.5 |
| M4 | 7 | -0.5 | 2.6 | ±0.15 | 4.2 | 2.3 | 1 | | 1.6 | +0.25 | 0.2 | 4.0 | 1.93 | 1.35 | JMR M4.0 |
| M4.5 | 8 | 0 | 3 | | 4.8 | 2.7 | 1 | | 1.9 | +0.3 | 0.2 | 4.4 | 2.33 | 1.74 | JMR M4.5 |
| M5 | 9 | -0.6 | 3.4 | | 5.4 | 3 | 1.2 | | 2.1 | | 0.2 | 4.7 | 2.63 | 2.04 | JMR M5.0 |
| M6 | 10.5 | 0 | 4 | ±0.2 | 6.3 | 3.5 | 1.2 | +0.2 | 2.5 | +0.4 | 0.25 | 6.1 | 2.78 | 2.16 | JMR M6.0 |
| M8 | 14 | 0 | 5.4 | | 8.4 | 4.8 | 1.6 | 0 | 3.3 | +0.5 | 0.4 | 7.6 | 4.26 | 3.63 | JMR M8.0 |

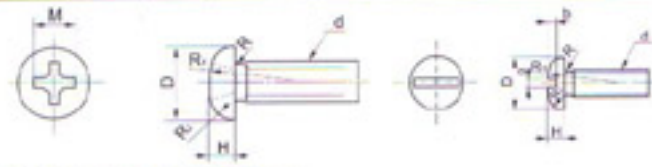
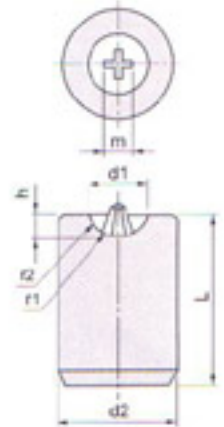

JWF (JIS FLAT HEAD WOOD SCREW)

| 規格 | d | | D | | H | | C | a | | b | | M | Q | 打字 | |
|-----|-----|-------|------|------|------|------|------|-----|-------|-----|-------|------|------|------|----------|
| | 公差 | 許容差 | 公差 | 許容差 | 公差 | 許容差 | 約 | 公差 | 許容差 | 公差 | 許容差 | 最大 | 最大 | | 最小 |
| 1.6 | 1.6 | +0.05 | 3.2 | | 0.95 | | 0.15 | 0.4 | | 0.4 | | | | | |
| 1.8 | 1.8 | | 3.6 | | 1.05 | | 0.15 | 0.6 | +0.15 | 0.5 | +0.1 | | | | |
| 2.1 | 2.1 | | 4.2 | 0 | 1.25 | 0 | 0.2 | 0.6 | 0 | 0.5 | | 2.5 | 1.32 | 0.95 | JWF M2.1 |
| 2.4 | 2.4 | +0.07 | 4.8 | -0.4 | 1.4 | -0.2 | 0.2 | 0.7 | | 0.6 | | 2.7 | 1.52 | 1.14 | JWF M2.4 |
| 2.7 | 2.7 | | 5.4 | | 1.55 | | 0.2 | 0.8 | | 0.7 | +0.15 | 2.9 | 1.72 | 1.34 | JWF M2.7 |
| 3.1 | 3.1 | | 6.2 | | 1.8 | | 0.25 | 0.9 | | 0.8 | | 3.6 | 1.73 | 1.20 | JWF M3.1 |
| 3.5 | 3.5 | | 7 | 0 | 2 | 0 | 0.25 | 1 | | 0.9 | | 4.2 | 2.13 | 1.60 | JWF M3.5 |
| 3.8 | 3.8 | +0.1 | 7.6 | -0.5 | 2.15 | -0.3 | 0.25 | 1 | | 0.9 | +0.2 | 4.5 | 2.43 | 1.89 | JWF M3.8 |
| 4.1 | 4.1 | | 8.2 | | 2.35 | | 0.3 | 1.2 | +0.2 | 1 | | 4.8 | 2.73 | 2.19 | JWF M4.1 |
| 4.5 | 4.5 | | 9 | 0 | 2.55 | 0 | 0.3 | 1.2 | 0 | 1.1 | | 5.2 | 3.13 | 2.58 | JWF M4.5 |
| 4.8 | 4.8 | +0.12 | 9.6 | -0.6 | 2.7 | -0.4 | 0.3 | 1.3 | | 1.2 | +0.25 | 5.4 | 3.33 | 2.77 | JWF M4.8 |
| 5.1 | 5.1 | | 10.2 | | 2.85 | | 0.3 | 1.4 | | 1.2 | | 6.4 | 3.06 | 2.50 | JWF M5.1 |
| 5.5 | 5.5 | | 11 | | 3.05 | | 0.3 | 1.4 | | 1.3 | | 6.7 | 3.36 | 2.80 | JWF M5.5 |
| 5.8 | 5.8 | | 11.6 | | 3.2 | | 0.3 | 1.6 | | 1.4 | | 7.0 | 3.66 | 3.09 | JWF M5.8 |
| 6.2 | 6.2 | +0.15 | 12.4 | -0.7 | 3.5 | -0.4 | 0.4 | 1.6 | | 1.5 | +0.3 | 7.3 | 3.96 | 3.39 | JWF M6.2 |
| 6.6 | 6.6 | | 13.6 | | 3.8 | | 0.4 | 1.6 | +0.25 | 1.6 | | 7.8 | 4.46 | 3.87 | JWF M6.8 |
| 7.5 | 7.5 | | 15 | 0 | 4.15 | 0 | 0.4 | 1.8 | 0 | 1.8 | +0.35 | 9.0 | 4.65 | 4.11 | JWF M7.5 |
| 8 | 8 | | 16 | | 4.4 | | 0.4 | 1.8 | | 1.9 | | 9.3 | 4.95 | 4.41 | JWF M8.0 |
| 9.5 | 9.5 | | 19 | -0.8 | 5.15 | | 0.4 | 2 | +0.3 | 2.2 | +0.4 | 10.3 | 5.95 | 5.39 | JWF M9.5 |

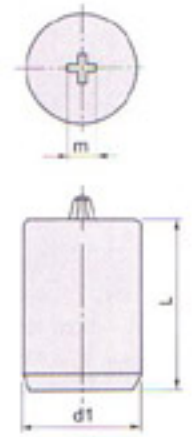

JWO (JIS OVAL HEAD WOOD SCREW)

| 规格 | d | | D | | H | | C | | K | | H+K | | a | | b | | M | | | Q | | | 打字 |
|-----|------|-------|------|-----------|------|-----------|------|-----|------|------|------|-----|-------|-----|-------|----|----|------|------|------|----|----------|----|
| | 基本尺寸 | 公差 | 基本尺寸 | 公差 | 基本尺寸 | 公差 | 约 | 约 | 基本尺寸 | 公差 | 基本尺寸 | 公差 | 基本尺寸 | 公差 | 最大 | 最大 | 最大 | 最大 | 最小 | 最大 | 最大 | 最小 | |
| 1.6 | 1.6 | | 3.2 | | 0.95 | | 0.15 | 0.4 | 1.35 | 0 | | 0.4 | | 0.7 | +0.1 | | | | | | | | |
| 1.8 | 1.8 | +0.05 | 3.6 | | 1.05 | | 0.15 | 0.4 | 1.45 | -0.3 | | 0.6 | +0.15 | 0.7 | | | | | | | | | |
| 2.1 | 2.1 | | 4.2 | 0 -0.4 | 1.25 | 0 -0.2 | 0.2 | 0.5 | 1.75 | | | 0.6 | 0 | 0.9 | | | | 2.7 | 1.52 | 1.14 | | JWO M2.1 | |
| 2.4 | 2.4 | +0.07 | 4.8 | | 1.4 | | 0.2 | 0.6 | 2 | -0.4 | | 0.7 | | 1 | +0.15 | | | 2.9 | 1.72 | 1.34 | | JWO M2.4 | |
| 2.7 | 2.7 | | 5.4 | | 1.55 | | 0.2 | 0.7 | 2.25 | | | 0.8 | | 1.1 | | | | 3.1 | 1.92 | 1.54 | | JWO M2.7 | |
| 3.1 | 3.1 | | 6.2 | | 1.8 | | 0.25 | 0.8 | 2.6 | | | 0.9 | | 1.3 | +0.2 | | | 3.9 | 1.83 | 1.30 | | JWO M3.1 | |
| 3.5 | 3.5 | | 7 | 0 -0.5 | 2 | | 0.25 | 0.8 | 2.8 | | | 1 | | 1.4 | | | | 4.3 | 2.23 | 1.69 | | JWO M3.5 | |
| 3.8 | 3.8 | +0.1 | 7.6 | | 2.15 | | 0.25 | 0.9 | 3.05 | | | 1 | | 1.5 | +0.25 | | | 4.6 | 2.53 | 1.99 | | JWO M3.8 | |
| 4.1 | 4.1 | | 8.2 | | 2.35 | 0 -0.3 | 0.3 | 1 | 3.35 | -0.5 | | 1.2 | +0.2 | 1.7 | | | | 4.9 | 2.83 | 2.28 | | JWO M4.1 | |
| 4.5 | 4.5 | | 9 | | 2.55 | | 0.3 | 1.1 | 3.65 | | | 1.2 | | 1.8 | | | | 5.3 | 3.23 | 2.68 | | JWO M4.5 | |
| 4.8 | 4.8 | | 9.6 | 0 -0.6 | 2.7 | | 0.3 | 1.1 | 3.8 | | | 1.3 | | 1.9 | +0.3 | | | 5.5 | 3.43 | 2.87 | | JWO M4.8 | |
| 5.1 | 5.1 | | 10.2 | | 2.85 | | 0.3 | 1.2 | 4.05 | | | 1.4 | | 2 | | | | 6.5 | 3.16 | 2.60 | | JWO M5.1 | |
| 5.5 | 5.5 | +0.12 | 11 | | 3.05 | | 0.3 | 1.3 | 4.35 | | | 1.4 | | 2.2 | | | | 6.8 | 3.46 | 2.90 | | JWO M5.5 | |
| 5.8 | 5.8 | | 11.6 | | 3.2 | | 0.3 | 1.4 | 4.6 | | | 1.6 | | 2.3 | +0.4 | | | 7.1 | 3.76 | 3.19 | | JWO M5.8 | |
| 6.2 | 6.2 | | 12.4 | 0 -0.7 | 3.5 | | 0.4 | 1.4 | 4.9 | | | 1.6 | | 2.5 | | | | 7.4 | 4.06 | 3.48 | | JWO M6.2 | |
| 6.8 | 6.8 | | 13.6 | | 3.8 | 0 -0.4 | 0.4 | 1.6 | 5.4 | -0.6 | | 1.6 | +0.25 | 2.7 | | | | 7.9 | 4.56 | 3.97 | | JWO M6.8 | |
| 7.5 | 7.5 | +0.15 | 15 | | 4.15 | | 0.4 | 1.8 | 5.95 | | | 1.8 | | 3 | +0.5 | | | 9.2 | 4.85 | 4.31 | | JWO M7.5 | |
| 8 | 8 | | 16 | 0 -0.8 | 4.4 | | 0.4 | 1.8 | 6.2 | | | 1.8 | | 3.1 | | | | 9.5 | 5.15 | 4.60 | | JWO M8.0 | |
| 9.5 | 9.5 | | 19 | | 5.15 | | 0.4 | 2.3 | 7.45 | | | 2 | +0.3 | 3.7 | | | | 10.5 | 6.15 | 5.58 | | JWO M9.5 | |

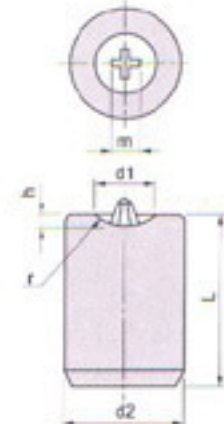

JWR (JIS ROUND HEAD WOOD SCREW)

| 规格 | d | | D | | H | | R ₁ | | R ₂ | | a | | b | | M | | | Q | | | 打字 | | |
|-----|------|-------|------|-------|------|-------|----------------|-----|----------------|-------|------|-----|-------|-----|------|------|----|----|----|----|----|----------|----|
| | 基本尺寸 | 公差 | 基本尺寸 | 公差 | 基本尺寸 | 公差 | 约 | 约 | 基本尺寸 | 公差 | 基本尺寸 | 公差 | 基本尺寸 | 公差 | 最大 | 最大 | 最大 | 最大 | 最小 | 最大 | | 最大 | 最小 |
| 1.6 | 1.6 | | 3 | | 1.3 | | 1.6 | 1.1 | 0.4 | | | 0.8 | +0.1 | | | | | | | | | | |
| 1.8 | 1.8 | +0.05 | 3.3 | | 1.4 | | 1.8 | 1.2 | 0.6 | +0.15 | | 0.9 | | | | | | | | | | | |
| 2.1 | 2.1 | | 3.9 | +0.2 | 1.6 | +0.1 | 2.3 | 1.4 | 0.6 | 0 | | 1 | +0.15 | 2.5 | 1.32 | 0.90 | | | | | | JWR M2.1 | |
| 2.4 | 2.4 | +0.07 | 4.4 | | 1.8 | | 2.6 | 1.5 | 0.7 | | | 1.1 | | 2.7 | 1.52 | 1.10 | | | | | | JWR M2.4 | |
| 2.7 | 2.7 | | 5 | | 2 | | 3 | 1.7 | 0.8 | | | 1.2 | +0.2 | 2.9 | 1.72 | 1.29 | | | | | | JWR M2.7 | |
| 3.1 | 3.1 | | 5.7 | | 2.3 | | 3.4 | 1.9 | 0.9 | | | 1.4 | | 3.7 | 1.63 | 1.06 | | | | | | JWR M3.1 | |
| 3.5 | 3.5 | | 6.5 | +0.25 | 2.5 | | 4 | 2.1 | 1 | | | 1.6 | +0.25 | 3.9 | 1.83 | 1.25 | | | | | | JWR M3.5 | |
| 3.8 | 3.8 | +0.1 | 7 | | 2.7 | | 4.4 | 2.3 | 1 | | | 1.7 | | 4.1 | 2.03 | 1.45 | | | | | | JWR M3.8 | |
| 4.1 | 4.1 | | 7.8 | | 2.9 | +0.15 | 4.8 | 2.4 | 1.2 | +0.2 | | 1.8 | | 4.3 | 2.23 | 1.64 | | | | | | JWR M4.1 | |
| 4.5 | 4.5 | | 8.3 | | 3.1 | | 5.2 | 2.6 | 1.2 | 0 | | 1.9 | +0.3 | 4.5 | 2.43 | 1.84 | | | | | | JWR M4.5 | |
| 4.8 | 4.8 | | 8.9 | +0.3 | 3.3 | | 5.7 | 2.8 | 1.3 | | | 2 | | 4.7 | 2.63 | 2.04 | | | | | | JWR M4.8 | |
| 5.1 | 5.1 | | 9.4 | | 3.5 | | 6 | 2.9 | 1.4 | | | 2.2 | | 5.9 | 2.56 | 1.96 | | | | | | JWR M5.1 | |
| 5.5 | 5.5 | +0.12 | 10.2 | | 3.8 | | 6.5 | 3.2 | 1.4 | | | 2.4 | +0.4 | 6.1 | 2.76 | 2.16 | | | | | | JWR M5.5 | |
| 5.8 | 5.8 | | 10.7 | | 4 | | 6.9 | 3.3 | 1.6 | | | 2.5 | | 6.3 | 2.96 | 2.36 | | | | | | JWR M5.8 | |
| 6.2 | 6.2 | | 11.5 | +0.35 | 4.2 | | 7.4 | 3.5 | 1.6 | | | 2.6 | | 6.6 | 3.26 | 2.65 | | | | | | JWR M6.2 | |
| 6.8 | 6.8 | | 12.6 | | 4.6 | +0.2 | 8.2 | 3.8 | 1.6 | +0.25 | | 2.8 | | 6.9 | 3.56 | 2.93 | | | | | | JWR M6.8 | |
| 7.5 | 7.5 | +0.15 | 13.9 | | 5 | | 9.1 | 4.2 | 1.8 | | | 3.1 | +0.5 | 8.4 | 4.05 | 3.48 | | | | | | JWR M7.5 | |
| 8 | 8 | | 14.8 | +0.4 | 5.3 | | 9.7 | 4.4 | 1.8 | | | 3.3 | | 8.7 | 4.35 | 3.77 | | | | | | JWR M8.0 | |
| 9.5 | 9.5 | | 17.6 | | 6.3 | | 11.6 | 5.2 | 2 | +0.3 | | 3.9 | | 9.7 | 5.35 | 4.75 | | | | | | JWR M9.5 | |

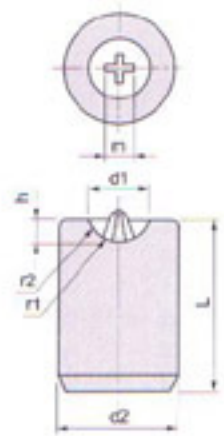

DMF (DIN FLAT HEAD MACHINE SCREW) <DIN 965>

| d1 | | M 2.5 | M 3 | (M 3.5) | M 4 | M 5 | M 6 | M 8 | M 10 |
|--------------|------|----------|----------|----------|----------|----------|----------|----------|-----------|
| d2 | | 4.7 | 5.6 | 6.5 | 7.5 | 9.2 | 11 | 14.5 | 18 |
| | 公差 | +0-0.3 | | | +0-0.36 | | | +0-0.43 | |
| k | max. | 1.5 | 1.65 | 1.93 | 2.2 | 2.5 | 3 | 4 | 5 |
| r | max. | 0.7 | 0.8 | 0.95 | 1 | 1.3 | 1.6 | 2 | 2.5 |
| PUNCH | | 1 | | | 2 | | | 3 | |
| m | | 2.7 | 2.9 | 3.9 | 4.4 | 4.6 | 6.6 | 8.7 | 9.6 |
| Q | min. | 1.25 | 1.5 | 1.4 | 1.9 | 2.1 | 2.8 | 3.9 | 4.8 |
| | max. | 1.55 | 1.8 | 1.9 | 2.4 | 2.6 | 3.3 | 4.4 | 5.3 |
| n | | 0.6 | 0.8 | 0.8 | 1 | 1.2 | 1.6 | 2 | 2.5 |
| r | max. | 0.25 | 0.3 | 0.35 | 0.4 | 0.5 | 0.6 | 0.8 | 1 |
| t | min. | 0.5 | 0.6 | 0.7 | 0.8 | 1 | 1.2 | 1.6 | 2 |
| | max. | 0.7 | 0.85 | 1 | 1.1 | 1.3 | 1.6 | 2.1 | 2.6 |
| ⊕ PUNCH CODE | | DMF M2.5 | DMF M3.0 | DMF M3.5 | DMF M4.0 | DMF M5.0 | DMF M6.0 | DMF M8.0 | DMF M10.0 |

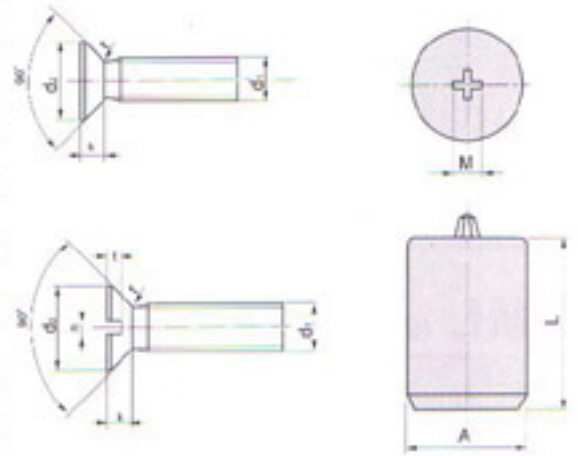

DMO (DIN OVAL HEAD MACHINE SCREW) <DIN 966>

| d1 | | M 2.5 | M 3 | (M 3.5) | M 4 | M 5 | M 6 | M 8 | M 10 |
|--------------|------|----------|----------|----------|----------|----------|----------|----------|-----------|
| d2 | | 4.7 | 5.6 | 6.5 | 7.5 | 9.2 | 11 | 14.5 | 18 |
| | 公差 | +0-0.3 | | | +0-0.36 | | | +0-0.43 | |
| f | ≈ | 0.6 | 0.75 | 0.9 | 1 | 1.25 | 1.5 | 2 | 2.5 |
| k | max. | 1.5 | 1.65 | 1.93 | 2.2 | 2.5 | 3 | 4 | 5 |
| r1 | ≈ | 5 | 6 | 7 | 8 | 10 | 12 | 16 | 20 |
| r2 | max. | 0.7 | 0.8 | 0.95 | 1 | 1.3 | 1.6 | 2 | 2.5 |
| PUNCH | | 1 | | | 2 | | | 3 | |
| m | | 2.7 | 3.1 | 4.2 | 4.5 | 5.3 | 6.8 | 9 | 10 |
| Q | min. | 1.3 | 1.7 | 1.74 | 2.04 | 2.77 | 3.03 | 4.18 | 5.38 |
| | max. | 1.6 | 2 | 2.24 | 2.54 | 3.27 | 3.53 | 4.68 | 5.88 |
| n | | 0.6 | 0.8 | 0.8 | 1 | 1.2 | 1.6 | 2 | 2.5 |
| r2 | max. | 0.25 | 0.3 | 0.35 | 0.4 | 0.5 | 0.6 | 0.8 | 1 |
| t | min. | 1 | 1.2 | 1.4 | 1.6 | 2 | 2.4 | 3.2 | 4 |
| | max. | 1.2 | 1.45 | 1.7 | 1.9 | 2.3 | 2.8 | 3.7 | 4.6 |
| ⊕ PUNCH CODE | | DMO M2.5 | DMO M3.0 | DMO M3.5 | DMO M4.0 | DMO M5.0 | DMO M6.0 | DMO M8.0 | DMO M10.0 |

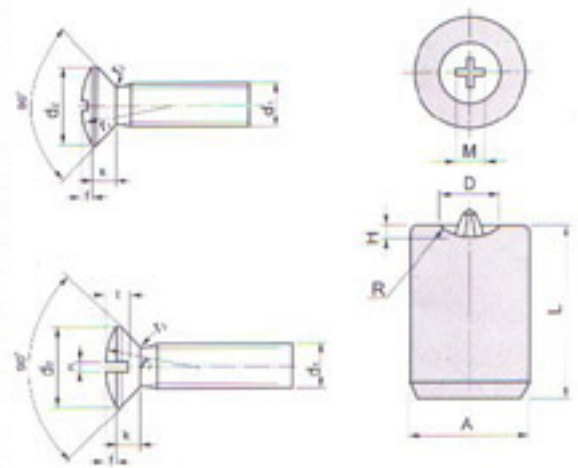

DMC (DIN CHEESE HEAD MACHINE SCREW) <DIN 84>

| d1 | | M 2 | (M 2.3) | M 2.5 | (M 2.6) | M 3 | (M 3.5) | M 4 | M 5 | M 6 | M 8 | M 10 | |
|------------|------|------------|------------|------------|------------|------------|------------|------------|------------|------------|------------|-------------|--|
| d2 | | 3.8 | 4.4 | 4.5 | 5 | 5.5 | 6 | 7 | 8.5 | 10 | 13 | 16 | |
| | 公差 | +0-0.18 | | | | | | +0-0.22 | | | +0-0.27 | | |
| k | | 1.3 | 1.5 | 1.6 | 1.7 | 2 | 2.4 | 2.6 | 3.3 | 3.9 | 5 | 6 | |
| | 公差 | +0-0.14 | | | | | | +0-0.18 | | | | | |
| n | | 0.5 | 0.6 | 0.6 | 0.6 | 0.8 | 0.8 | 1 | 1.2 | 1.6 | 2 | 2.5 | |
| t | min. | 0.6 | 0.7 | 0.7 | 0.8 | 0.9 | 1.1 | 1.2 | 1.5 | 1.8 | 2.1 | 2.4 | |
| | max. | 0.8 | 0.9 | 0.9 | 1 | 1.15 | 1.4 | 1.5 | 1.8 | 2.2 | 2.6 | 3 | |
| PUNCH CODE | | DMC-B M2.0 | DMC-B M2.3 | DMC-B M2.5 | DMC-B M2.6 | DMC-B M3.0 | DMC-B M3.5 | DMC-B M4.0 | DMC-B M5.0 | DMC-B M6.0 | DMC-B M8.0 | DMC-B M10.0 | |

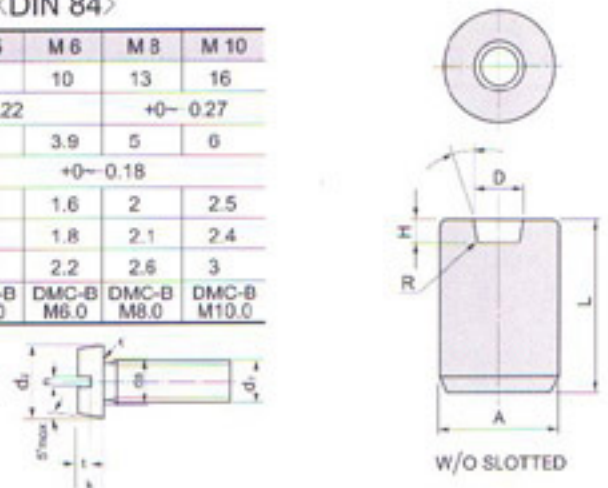

DMP (DIN PAN HEAD MACHINE SCREW) <DIN 85>

| d1 | M 3 | (M 3.5) | M 4 | M 5 | M 6 | (M 8) | (M 10) |
|--------------|------------|------------|----------|----------|----------|----------|-----------|
| d2 | 公差 +0-0.18 | | +0-0.22 | | +0-0.27 | | +0-0.33 |
| k | 公差 +0.125 | | | | +0.15 | | |
| n | 0.8 | 0.8 | 1 | 1.2 | 1.6 | 2 | 2.5 |
| r1 | max. | 1.2 | 1.4 | 1.6 | 2 | 2.4 | 3.2 |
| | min. | 0.6 | 0.7 | 0.8 | 1 | 1.2 | 1.6 |
| t | min. | 0.7 | 0.8 | 1 | 1.2 | 1.5 | 1.9 |
| | max. | 0.95 | 1.1 | 1.3 | 1.5 | 1.9 | 2.4 |
| ⊖ PUNCH CODE | DMP-C M3 | DMP-C M3.5 | DMP-C M4 | DMP-C M5 | DMP-C M6 | DMP-C M8 | DMP-C M10 |

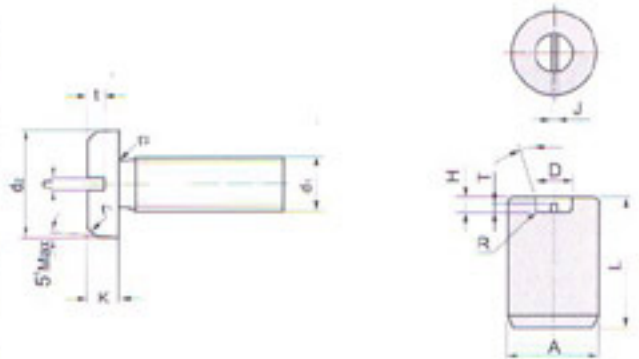

DML (DIN FILLISTER HEAD MACHINE SCREW) <DIN 7985>

| d1 | M 2 | M 2.5 | M 3 | (M 3.5) | M 4 | M 5 | M 6 | M 8 | M 10 |
|--------------|------------|----------|--------|----------|--------|---------|--------|---------|---------|
| d2 | 公差 +0-0.18 | | | +0-0.22 | | +0-0.27 | | +0-0.33 | |
| k | 公差 +0.125 | | | | +0.15 | | | | |
| r1 | 4 | 5 | 6 | 7 | 8 | 10 | 12 | 16 | 20 |
| v | 1.1 | 1.3 | 1.6 | 1.9 | 2 | 2.5 | 3 | 3.7 | 4.8 |
| PUNCH | 1 | | | 2 | | 3 | | | 4 |
| | m | 2.5 | 2.7 | 3.1 | 4.2 | 4.6 | 5.3 | 6.8 | 9 |
| Q | min. | 1.1 | 1.3 | 1.7 | 1.74 | 2.04 | 2.77 | 3.03 | 4.18 |
| | max. | 1.4 | 1.6 | 2 | 2.24 | 2.54 | 3.27 | 3.53 | 4.68 |
| ⊖ PUNCH CODE | DML M2 | DML M2.5 | DML M3 | DML M3.5 | DML M4 | DML M5 | DML M6 | DML M8 | DML M10 |

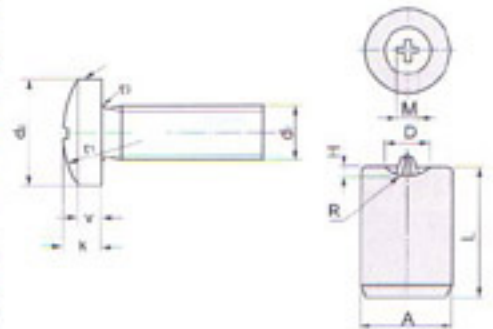

DTF (DIN FLAT HEAD TAPPING SCREW) <DIN 7982>

| SIZE | 2.2 | 2.9 | 3.5 | (3.9) | 4.2 | 4.8 | (5.5) | 6.3 |
|--------------|----------|------------|---------|---------|-------------|---------|---------|---------|
| d | 4.3 | 5.5 | 6.8 | 7.5 | 8.1 | 9.5 | 10.8 | 12.4 |
| k | 1.3 | 1.7 | 2.1 | 2.3 | 2.5 | 3 | 3.4 | 3.8 |
| r | max. 0.8 | 1.1 | 1.4 | 1.5 | 1.6 | 1.9 | 2.1 | 2.4 |
| PUNCH | 1 | | | 2 | | 3 | | |
| | m | 2.5 | 3 | 4.2 | 4.6 | 4.7 | 5.1 | 6.8 |
| Q | min. | 1.02 | 1.4 | 1.62 | 2.03 | 2.11 | 2.59 | 2.95 |
| | max. | 1.32 | 1.7 | 2.12 | 2.53 | 2.62 | 3.1 | 3.53 |
| n | 公差 | +0.06→+0.2 | | | +0.06→+0.31 | | | |
| | r | max. 0.8 | 1.1 | 1.4 | 1.5 | 1.6 | 1.9 | 2.1 |
| t | min. | 0.4 | 0.6 | 0.8 | 0.7 | 0.75 | 0.85 | 1 |
| | max. | 0.6 | 0.75 | 0.95 | 1.05 | 1.15 | 1.35 | 1.5 |
| ⊕ PUNCH CODE | DTF 2.2 | DTF 2.9 | DTF 3.5 | DTF 3.9 | DTF 4.2 | DTF 4.8 | DTF 5.5 | DTF 6.3 |

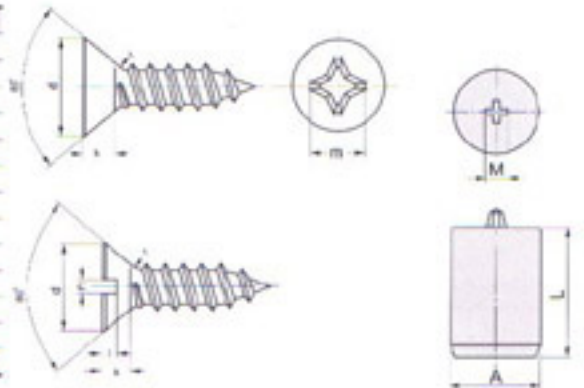

DTO (DIN OVAL HEAD TAPPING SCREW) <DIN 7983>

| SIZE | 2.2 | 2.9 | 3.5 | (3.9) | 4.2 | 4.8 | (5.5) | 6.3 |
|--------------|----------|------------|---------|---------|-------------|---------|---------|---------|
| d | 4.3 | 5.5 | 6.8 | 7.5 | 8.1 | 9.5 | 10.8 | 12.4 |
| f | 0.7 | 0.9 | 1.2 | 1.3 | 1.4 | 1.5 | 1.7 | 2 |
| k | 1.3 | 1.7 | 2.1 | 2.3 | 2.5 | 3 | 3.4 | 3.8 |
| r1 | max. 0.8 | 1.1 | 1.4 | 1.5 | 1.6 | 1.9 | 2.1 | 2.4 |
| r2 | 0.8 | 4.6 | 5.4 | 6 | 6.6 | 8.2 | 9.4 | 11.1 |
| PUNCH | 1 | | | 2 | | 3 | | |
| | m | 2.8 | 3.4 | 4.6 | 4.7 | 4.9 | 5.4 | 7 |
| Q | min. | 1.17 | 1.81 | 1.89 | 2.04 | 2.24 | 2.7 | 3.02 |
| | max. | 1.57 | 2.21 | 2.39 | 2.54 | 2.74 | 3.2 | 3.53 |
| n | 公差 | +0.06→+0.2 | | | +0.06→+0.31 | | | |
| | t | min. 0.95 | 1.25 | 1.55 | 1.7 | 1.85 | 2.15 | 2.45 |
| t | max. | 1.15 | 1.5 | 1.9 | 2.05 | 2.25 | 2.6 | 2.95 |
| | max. | 1.15 | 1.5 | 1.9 | 2.05 | 2.25 | 2.6 | 2.95 |
| ⊕ PUNCH CODE | DTO 2.2 | DTO 2.9 | DTO 3.5 | DTO 3.9 | DTO 4.2 | DTO 4.8 | DTO 5.5 | DTO 6.3 |

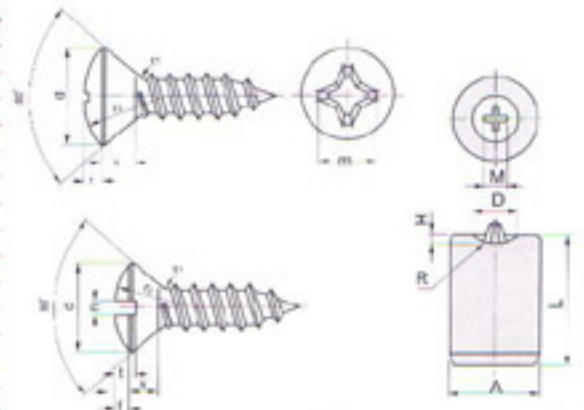

DTP (DIN PAN HEAD TAPPING SCREW) <DIN 7981>

| SIZE | 2.2 | 2.9 | 3.5 | (3.9) | 4.2 | 4.8 | (5.5) | 6.3 |
|--------------|---------|---------|----------|---------|---------|----------|---------|---------|
| d | 4.2 | 5.6 | 6.9 | 7.5 | 8.2 | 9.5 | 10.8 | 12.5 |
| 公差 | +0- 0.3 | | +0- 0.36 | | | +0- 0.43 | | |
| K | max. | 1.8 | 2.2 | 2.6 | 2.8 | 3.05 | 3.55 | 4.55 |
| | min. | 1.65 | 1.95 | 2.35 | 2.55 | 2.75 | 3.25 | 4.25 |
| r1 | max. | 0.3 | 0.4 | 0.5 | 0.5 | 0.6 | 0.7 | 0.9 |
| r2 | ≈ | 3.4 | 4.4 | 5.4 | 5.8 | 6.2 | 7.2 | 8.2 |
| PUNCH | 1 | | 2 | | | 3 | | |
| m | 2.6 | 3 | 4.2 | 4.4 | 4.6 | 5 | 6.5 | 7.1 |
| Q | min. | 0.86 | 1.35 | 1.4 | 1.63 | 1.8 | 2.26 | 2.49 |
| | max. | 1.32 | 1.8 | 2.03 | 2.26 | 2.46 | 2.87 | 3.15 |
| ⊕ PUNCH CODE | DTP 2.2 | DTP 2.9 | DTP 3.5 | DTP 3.9 | DTP 4.2 | DTP 4.8 | DTP 5.5 | DTP 6.3 |

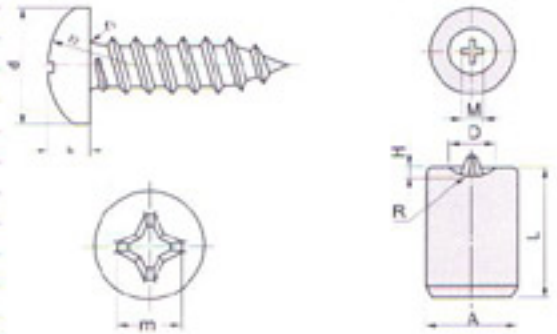

DTP (DIN PAN HEAD TAPPING SCREW) <DIN 7971>

| SIZE | 2.2 | 2.9 | 3.5 | (3.9) | 4.2 | 4.8 | (5.5) | 6.3 |
|--------------|----------|-----------|----------|----------|------------|----------|----------|----------|
| d | 4.2 | 5.6 | 6.9 | 7.5 | 8.2 | 9.5 | 10.8 | 12.5 |
| 公差 | +0- 0.3 | | +0- 0.36 | | | +0- 0.43 | | |
| k | max. | 1.35 | 1.75 | 2.1 | 2.25 | 2.45 | 2.8 | 3.65 |
| | min. | 1.15 | 1.5 | 1.85 | 2 | 2.15 | 2.5 | 3.3 |
| n | 公差 | +0.06-0.2 | | | +0.06-0.31 | | | |
| r1 | max. | 0.3 | 0.4 | 0.5 | 0.5 | 0.6 | 0.7 | 0.8 |
| r3 | ≈ | 0.9 | 1 | 1.2 | 1.3 | 1.3 | 1.6 | 2 |
| t | min. | 0.55 | 0.75 | 0.95 | 1.05 | 1.15 | 1.35 | 1.55 |
| | max. | 0.8 | 1 | 1.25 | 1.4 | 1.5 | 1.7 | 1.95 |
| ⊖ PUNCH CODE | DTP-C2.2 | DTP-C2.9 | DTP-C3.5 | DTP-C3.9 | DTP-C4.2 | DTP-C4.8 | DTP-C5.5 | DTP-C6.3 |

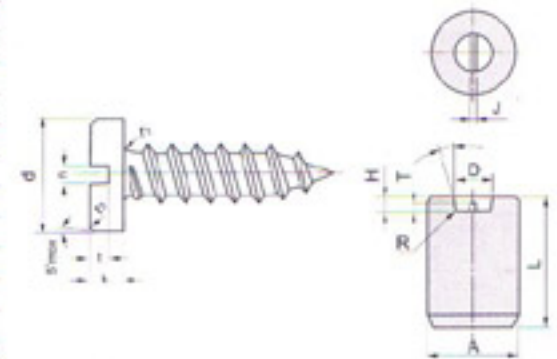

DWF (DIN FLAT HEAD WOOD SCREW) <DIN 7997>

| d1 | (2) | 2.5 | 3 | 3.5 | 4 | 4.5 | 5 | (5.5) | 6 | (7) | (8) |
|--------------|---------|-------------|---------|---------|---------|-------------|---------|---------|---------|---------|---------|
| d2 | 3.8 | 4.7 | 5.6 | 6.5 | 7.5 | 8.3 | 9.2 | 10.2 | 11 | 12.5 | 14.5 |
| 公差 | +0.375 | | | +0.45 | | | | +0.55 | | | |
| k | max. | 1.2 | 1.5 | 1.65 | 1.93 | 2.2 | 2.35 | 2.5 | 2.75 | 3 | 3.5 |
| PUNCH | | 1 | | 2 | | | 3 | | 4 | | |
| m | | 2.7 | 2.9 | 3.9 | 4.4 | 4.6 | 4.8 | 6.2 | 6.6 | 6.8 | 8.7 |
| | Q | Min. | 1.25 | 1.5 | 1.4 | 1.9 | 2.1 | 2.29 | 2.31 | 2.8 | 2.95 |
| Max. | | 1.55 | 1.8 | 1.9 | 2.4 | 2.6 | 2.79 | 2.81 | 3.3 | 3.53 | 4.4 |
| n | 公差 | +0.20-+0.06 | | | | +0.31-+0.06 | | | | | |
| t | min. | 0.4 | 0.5 | 0.6 | 0.7 | 0.8 | 0.9 | 1 | 1.1 | 1.2 | 1.4 |
| | max. | 0.6 | 0.7 | 0.85 | 1 | 1.1 | 1.2 | 1.3 | 1.4 | 1.6 | 1.9 |
| ⊕ PUNCH CODE | DWF 2.0 | DWF 2.5 | DWF 3.0 | DWF 3.5 | DWF 4.0 | DWF 4.5 | DWF 5.0 | DWF 5.5 | DWF 6.0 | DWF 7.0 | DWF 8.0 |



DWO (DIN OVAL HEAD WOOD SCREW) <DIN 7995>

| d1 | | (2) | 2.5 | 3 | 3.5 | 4 | 4.5 | 5 | (5.5) | 6 | (7) | (8) |
|-------|------------|-----|-------------|-------|---------|-------|-------------|-------|---------|-------|-------|-------|
| d2 | 公差 | 3.8 | 4.7 | 5.6 | 6.5 | 7.5 | 8.3 | 9.2 | 10.2 | 11 | 12.5 | 14.5 |
| f | no | 0.5 | 0.6 | 0.75 | 0.8 | 1 | 1.1 | 1.25 | 1.4 | 1.5 | 1.75 | 2 |
| k | max | 1.2 | 1.5 | 1.85 | 1.93 | 2.2 | 2.35 | 2.5 | 2.75 | 3 | 3.5 | 4 |
| r | no | 4 | 5 | 6 | 7 | 8 | 9 | 10 | 11 | 12 | 14 | 16 |
| PUNCH | | | 1 | | 2 | | | | 3 | | | 4 |
| m | Q | | 2.7 | 3.1 | 4.2 | 4.5 | 5.0 | 5.3 | 7.1 | 7.40 | 8.3 | 9.9 |
| | min | | 1.3 | 1.7 | 1.74 | 2.04 | 2.55 | 2.77 | 3.31 | 3.66 | 4.52 | 5.03 |
| | max | | 1.6 | 2.0 | 2.24 | 2.54 | 3.06 | 3.27 | 3.81 | 4.16 | 5.02 | 5.53 |
| n | 公差 | 0.5 | 0.6 | 0.8 | 0.8 | 1 | 1 | 1.2 | 1.2 | 1.6 | 2 | 2 |
| | min | | +0.20~+0.06 | | | | +0.31~+0.06 | | | | | |
| t | max | 0.8 | 1 | 1.2 | 1.4 | 1.6 | 1.8 | 2 | 2.2 | 2.4 | 2.8 | 3.2 |
| | max | 1 | 1.2 | 1.45 | 1.7 | 1.9 | 2.1 | 2.3 | 2.5 | 2.8 | 3.2 | 3.7 |
| ① | PUNCH CODE | | DWO 2.5 | DWO 3 | DWO 3.5 | DWO 4 | DWO 4.5 | DWO 5 | DWO 5.5 | DWO 6 | DWO 7 | DWO 8 |

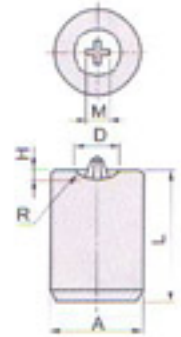

DWR (DIN ROUND HEAD WOOD SCREW) <DIN 7996>

| d1 | | (2) | 2.5 | 3 | 3.5 | 4 | 4.5 | 5 | (5.5) | 6 | (7) | (8) | |
|-------|------------|--------|-------------|-------|---------|-------|-------------|-------|---------|-------|-------|-------|--|
| d2 | 公差 | 4 | 5 | 6 | 7 | 8 | 9 | 10 | 11 | 12 | 14 | 16 | |
| | 公差 | +0.375 | | | | +0.45 | | | | +0.55 | | | |
| d3 | 公差 | 2.8 | 3.3 | 3.8 | 4.3 | 5 | 5.5 | 6 | 6.6 | 7.2 | 8.2 | 10.2 | |
| | 公差 | +0.2 | | | | +0.24 | | | | | | | |
| k | no | 1.4 | 1.7 | 2.1 | 2.4 | 2.8 | 3.1 | 3.5 | 3.8 | 4.2 | 4.9 | 5.6 | |
| r1 | no | 3.2 | 4 | 4.8 | 5.6 | 6.4 | 7.2 | 8 | 8.8 | 9.6 | 11.2 | 12.8 | |
| r2 | no | 1.6 | 2 | 2.4 | 2.8 | 3.2 | 3.6 | 4 | 4.4 | 4.8 | 5.6 | 6.4 | |
| PUNCH | | 0 | 1 | | 2 | | | | 3 | | | 4 | |
| m | Q | | 2.3 | 2.7 | 3.7 | 4.1 | 4.4 | 4.8 | 6.2 | 6.6 | 7.3 | 8.8 | |
| | min | | 0.85 | 1.3 | 1.22 | 1.62 | 1.88 | 2.28 | 2.42 | 2.82 | 3.52 | 3.93 | |
| | max | | 1.15 | 1.6 | 1.72 | 2.12 | 2.38 | 2.78 | 2.92 | 3.32 | 4.02 | 4.43 | |
| n | 公差 | 0.5 | 0.6 | 0.8 | 0.8 | 1 | 1 | 1.2 | 1.2 | 1.6 | 2 | 2 | |
| | min | | +0.20~+0.06 | | | | +0.31~+0.06 | | | | | | |
| t | max | 0.75 | 0.85 | 1.05 | 1.2 | 1.4 | 1.55 | 1.75 | 1.9 | 2.1 | 2.45 | 2.8 | |
| | max | 0.9 | 1.1 | 1.35 | 1.6 | 1.8 | 2 | 2.3 | 2.5 | 2.7 | 3.2 | 3.6 | |
| ① | PUNCH CODE | | DWR 2.5 | DWR 3 | DWR 3.5 | DWR 4 | DWR 4.5 | DWR 5 | DWR 5.5 | DWR 6 | DWR 7 | DWR 8 | |

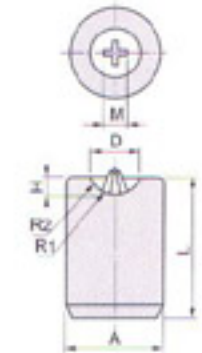

DMF(6H) (DIN FLAT HEX. RECELS SCREW) <DIN 7991>

| d1 | M 3 | M 4 | M 5 | M 6 | M 8 | M 10 | M 12 | (M 14) | M 16 | (M 18) | M 20 | (M 22) | M 24 | |
|------------|------------|------------|------------|------------|------------|-------------|-------------|--------|--------|--------|--------|--------|--------|--------|
| α | 90° | | | | | | | | | | | 60° | | |
| c | 0.2 | 0.3 | 0.3 | 0.3 | 0.4 | 0.5 | 0.5 | 0.5 | 0.5 | 0.5 | 0.5 | 1 | 1 | |
| d2 | 6 | 8 | 10 | 12 | 16 | 20 | 24 | 27 | 30 | 33 | 36 | 36 | 39 | |
| e no | 2.3 | 2.9 | 3.5 | 4.7 | 5.8 | 7 | 9.4 | 11.7 | 11.7 | 13.9 | 13.9 | 16.5 | 16.5 | |
| k | 1.7 | 2.3 | 2.8 | 3.3 | 4.4 | 5.5 | 6.5 | 7 | 7.5 | 8 | 8.5 | 13.1 | 14 | |
| r | 0.1 | 0.2 | 0.2 | 0.3 | 0.5 | 0.5 | 1 | 1 | 1 | 1 | 1 | 1 | 1.6 | |
| DMF ① | 2 | 2.5 | 3 | 4 | 5 | 6 | 8 | 10 | 10 | 12 | 12 | 14 | 14 | |
| s | min | 2.02 | 2.52 | 3.02 | 4.32 | 5.02 | 6.02 | 8.025 | 10.025 | 10.025 | 12.032 | 12.032 | 14.032 | 14.032 |
| | max | 2.10 | 2.60 | 3.10 | 4.12 | 5.14 | 6.14 | 8.175 | 10.175 | 10.175 | 12.212 | 12.212 | 14.212 | 14.212 |
| t | | 1.2 | 1.8 | 2.3 | 2.5 | 3.5 | 4.4 | 4.6 | 4.8 | 5.3 | 5.5 | 5.9 | 10.3 | |
| PUNCH CODE | DMF(6H)M 3 | DMF(6H)M 4 | DMF(6H)M 5 | DMF(6H)M 6 | DMF(6H)M 8 | DMF(6H)M 10 | DMF(6H)M 12 | | | | | | | |

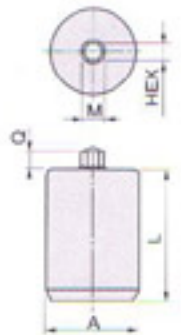

AMF (ANSI FLAT HEAD MACHINE & TAPPING SCREW)

| 規格 | 頭部外徑 | | 頭深 | 溝寬 | | 溝深 | | 沖模間隙 | | 螺寬 | 十字寬 | | # | 十字深 | | 打字 | |
|--------------|-------|-------|-------|------|------|------|------|------|------|------|-------|-------|-------|-------|------|------|----------|
| | 上限 | 下限 | | 參考 | 上限 | 下限 | 上限 | 下限 | 上限 | | 下限 | 上限 | | 下限 | 上限 | | 下限 |
| 0 | 1.52 | 3.02 | 2.51 | 0.89 | 0.58 | 0.41 | 0.38 | 0.25 | 0.66 | 0.41 | 1.98 | 1.75 | 1.42 | 0 | 0.91 | 0.51 | |
| 1 | 1.85 | 3.71 | 3.12 | 1.09 | 0.66 | 0.48 | 0.48 | 0.30 | 0.71 | 0.41 | 2.57 | 1.96 | 1.63 | 0 | 1.12 | 0.71 | |
| 2 | 2.18 | 4.37 | 3.73 | 1.30 | 0.79 | 0.58 | 0.58 | 0.38 | 0.74 | 0.43 | 3.15 | 2.59 | 2.26 | 1 | 1.42 | 1.02 | AMF 2# |
| 3 | 2.51 | 5.05 | 4.34 | 1.50 | 0.89 | 0.69 | 0.69 | 0.43 | 0.79 | 0.46 | 3.76 | 2.72 | 2.39 | 1 | 1.55 | 1.14 | AMF 3# |
| 4 | 2.84 | 5.72 | 4.95 | 1.70 | 0.99 | 0.79 | 0.76 | 0.51 | 0.81 | 0.48 | 4.37 | 3.25 | 2.92 | 1 | 2.08 | 1.68 | AMF 4# |
| 5 | 3.18 | 6.40 | 5.59 | 1.90 | 1.09 | 0.89 | 0.86 | 0.56 | 0.86 | 0.51 | 4.98 | 3.91 | 3.58 | 2 | 1.90 | 1.32 | AMF 5# |
| 6 | 3.51 | 7.09 | 6.20 | 2.11 | 1.22 | 0.99 | 0.97 | 0.61 | 0.91 | 0.53 | 5.59 | 4.42 | 4.09 | 2 | 2.41 | 1.83 | AMF 6# |
| 7 | 3.84 | 7.75 | 6.81 | 2.31 | 1.22 | 0.99 | 1.04 | 0.69 | 0.94 | 0.56 | 6.17 | 4.62 | 4.29 | 2 | 2.62 | 2.03 | AMF 7# |
| 8 | 4.17 | 8.43 | 7.42 | 2.54 | 1.37 | 1.14 | 1.14 | 0.74 | 0.99 | 0.58 | 6.78 | 4.80 | 4.47 | 2 | 2.79 | 2.21 | AMF 8# |
| 10 | 4.83 | 9.78 | 8.64 | 2.95 | 1.52 | 1.27 | 1.35 | 0.86 | 1.07 | 0.64 | 7.95 | 5.18 | 4.85 | 2 | 3.18 | 2.59 | AMF 10# |
| 12 | 5.49 | 11.13 | 9.88 | 3.35 | 1.70 | 1.42 | 1.52 | 0.99 | 1.14 | 0.69 | 9.19 | 6.81 | 6.48 | 3 | 3.53 | 2.95 | AMF 12# |
| 1/4 | 6.35 | 12.88 | 11.48 | 3.89 | 1.90 | 1.63 | 1.78 | 1.17 | 1.27 | 0.74 | 10.77 | 7.19 | 6.86 | 3 | 3.91 | 3.30 | AMF 1/4 |
| 5/16 | 7.94 | 16.13 | 14.43 | 4.85 | 2.13 | 1.83 | 2.24 | 1.47 | 1.45 | 0.86 | 13.69 | 9.27 | 8.94 | 4 | 4.98 | 4.42 | AMF 5/16 |
| 3/8 | 9.53 | 19.35 | 17.40 | 5.84 | 2.39 | 2.06 | 2.69 | 1.78 | 1.65 | 0.99 | 16.59 | 9.98 | 9.65 | 4 | 5.72 | 5.16 | AMF 3/8 |
| 7/16 | 11.11 | 20.62 | 18.36 | 5.66 | 2.39 | 2.06 | 2.62 | 1.68 | 1.85 | 1.12 | 17.53 | 10.39 | 10.06 | 4 | 6.12 | 5.56 | AMF 7/16 |
| 1/2 | 12.70 | 22.23 | 19.68 | 5.66 | 2.69 | 2.31 | 2.62 | 1.65 | 2.06 | 1.24 | 18.77 | 10.77 | 10.44 | 4 | 6.50 | 5.94 | AMF 1/2 |
| Nominal Size | Max. | Min. | Ref. | Max. | Min. | Max. | Min. | Max. | Min. | Max. | Min. | Max. | Min. | # | Max. | Min. | 打字 |
| | A | | H | J | | T | | F | | G | M | | | Depth | | | |

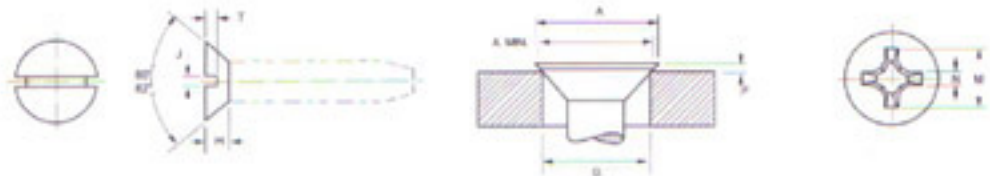
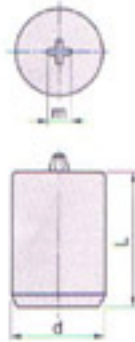

AMO (ANSI OVAL HEAD MACHINE & TAPPING SCREW)

| 規格 | 頭部外徑 | | 螺深 | 頭深 | | 溝寬 | | 溝深 | | 十字寬 | | # | 十字深 | | 打字 | | |
|--------------|-------|-------|-------|------|------|------|------|------|------|------|-------|-------|-------|------|------|----------|----|
| | 上限 | 下限 | | 參考 | 上限 | 下限 | 上限 | 下限 | 上限 | 下限 | 上限 | | 下限 | 上限 | | 下限 | |
| 0 | 1.52 | 3.02 | 2.51 | 0.89 | 1.42 | 1.04 | 0.58 | 0.41 | 0.76 | 0.54 | 1.88 | 1.55 | 0 | 0.97 | 0.51 | | |
| 1 | 1.85 | 3.71 | 3.12 | 1.09 | 1.73 | 1.32 | 0.66 | 0.48 | 0.97 | 0.79 | 1.96 | 1.63 | 0 | 1.04 | 0.58 | | |
| 2 | 2.18 | 4.37 | 3.73 | 1.30 | 2.03 | 1.60 | 0.79 | 0.58 | 1.14 | 0.94 | 2.64 | 2.51 | 1 | 1.57 | 1.14 | AMO 2# | |
| 3 | 2.51 | 5.05 | 4.34 | 1.50 | 2.34 | 1.85 | 0.89 | 0.69 | 1.32 | 1.09 | 3.15 | 2.82 | 1 | 1.88 | 1.45 | AMO 3# | |
| 4 | 2.84 | 5.72 | 4.95 | 1.70 | 2.64 | 2.13 | 0.99 | 0.79 | 1.50 | 1.24 | 3.45 | 3.12 | 1 | 2.21 | 1.78 | AMO 4# | |
| 5 | 3.18 | 6.40 | 5.59 | 1.90 | 2.95 | 2.41 | 1.09 | 0.89 | 1.70 | 1.40 | 4.01 | 3.68 | 2 | 1.88 | 1.27 | AMO 5# | |
| 6 | 3.51 | 7.09 | 6.20 | 2.11 | 3.25 | 2.67 | 1.22 | 0.99 | 1.88 | 1.52 | 4.52 | 4.19 | 2 | 2.39 | 1.75 | AMO 6# | |
| 7 | 3.84 | 7.75 | 6.81 | 2.31 | 3.56 | 2.95 | 1.22 | 0.99 | 2.06 | 1.68 | 4.65 | 4.32 | 2 | 2.54 | 1.90 | AMO 7# | |
| 8 | 4.17 | 8.43 | 7.42 | 2.54 | 3.86 | 3.20 | 1.37 | 1.14 | 2.24 | 1.83 | 4.88 | 4.55 | 2 | 2.74 | 2.13 | AMO 8# | |
| 10 | 4.83 | 9.78 | 8.64 | 2.95 | 4.47 | 3.76 | 1.52 | 1.27 | 2.62 | 2.13 | 5.31 | 4.98 | 2 | 3.20 | 2.59 | AMO 10# | |
| 12 | 5.49 | 11.13 | 9.88 | 3.35 | 5.08 | 4.29 | 1.70 | 1.42 | 2.97 | 2.44 | 6.06 | 5.53 | 3 | 3.43 | 2.82 | AMO 12# | |
| 1/4 | 6.35 | 12.88 | 11.48 | 3.89 | 5.89 | 5.00 | 1.90 | 1.63 | 3.45 | 2.84 | 7.37 | 7.04 | 3 | 3.96 | 3.33 | AMO 1/4 | |
| 5/16 | 7.94 | 16.13 | 14.43 | 4.85 | 7.37 | 6.32 | 2.13 | 1.83 | 4.34 | 3.58 | 9.91 | 9.58 | 4 | 5.54 | 4.93 | AMO 5/16 | |
| 3/8 | 9.53 | 19.35 | 17.40 | 5.84 | 8.81 | 7.62 | 2.39 | 2.06 | 5.23 | 4.32 | 10.41 | 10.08 | 4 | 6.02 | 5.41 | AMO 3/8 | |
| 7/16 | 11.11 | 20.62 | 18.36 | 5.66 | 8.76 | 7.49 | 2.39 | 2.06 | 5.33 | 4.42 | 10.72 | 10.39 | 4 | 6.32 | 5.72 | AMO 7/16 | |
| 1/2 | 12.70 | 22.23 | 19.68 | 5.66 | 8.99 | 7.59 | 2.69 | 2.31 | 5.49 | 4.47 | 11.10 | 10.77 | 4 | 6.68 | 6.07 | AMO 1/2 | |
| Nominal Size | Max. | Min. | Ref. | Max. | Min. | Max. | Min. | Max. | Min. | Max. | Min. | Max. | Min. | # | Max. | Min. | 打字 |
| | A | | H | O | | J | | T | | M | | | Depth | | | | |

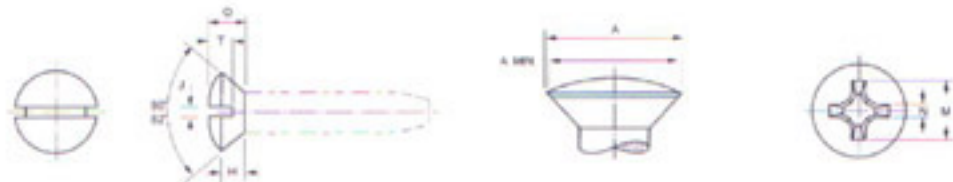
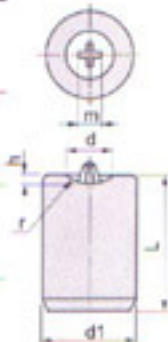

AMR (ANSI ROUND HEAD MACHINE & TAPPING SCREW)

| 規格 | 頭部外徑 | | 頭深 | | 溝寬 | | 溝深 | | 十字寬 | | # | 十字深 | | 打字 | | |
|--------------|-------|-------|-------|------|------|------|------|------|------|-------|-------|------|------|------|------------------|----|
| | 上限 | 下限 | 上限 | 下限 | 上限 | 下限 | 上限 | 下限 | 上限 | 下限 | | 上限 | 下限 | | | |
| 0 | 1.52 | 2.87 | 2.51 | 1.35 | 1.09 | 0.58 | 0.41 | 0.99 | 0.74 | 1.65 | 1.52 | 0 | 0.89 | 0.38 | AMR 2# AMR 3# | |
| 1 | 1.85 | 3.51 | 3.10 | 1.55 | 1.30 | 0.66 | 0.48 | 1.12 | 0.84 | 2.08 | 1.75 | 0 | 1.14 | 0.66 | | |
| 2 | 2.18 | 4.11 | 3.71 | 1.75 | 1.50 | 0.79 | 0.58 | 1.22 | 0.94 | 2.54 | 2.21 | 1 | 1.17 | 0.69 | | |
| 3 | 2.51 | 4.75 | 4.29 | 1.98 | 1.70 | 0.89 | 0.69 | 1.35 | 1.02 | 2.77 | 2.44 | 1 | 1.40 | 0.89 | | |
| 4 | 2.84 | 5.36 | 4.90 | 2.18 | 1.90 | 0.99 | 0.79 | 1.47 | 1.12 | 3.00 | 2.67 | 1 | 1.65 | 1.17 | AMR 4# | |
| 5 | 3.18 | 5.99 | 5.51 | 2.41 | 2.11 | 1.09 | 0.89 | 1.60 | 1.19 | 3.91 | 3.58 | 2 | 1.60 | 0.89 | AMR 5# | |
| 6 | 3.51 | 6.60 | 6.10 | 2.62 | 2.31 | 1.22 | 0.99 | 1.73 | 1.30 | 4.11 | 3.78 | 2 | 1.85 | 1.14 | AMR 6# | |
| 7 | 3.84 | 7.24 | 6.71 | 2.82 | 2.51 | 1.22 | 0.99 | 1.83 | 1.40 | 4.32 | 3.99 | 2 | 2.06 | 1.40 | AMR 7# | |
| 8 | 4.17 | 7.85 | 7.29 | 3.05 | 2.72 | 1.37 | 1.14 | 1.95 | 1.47 | 4.52 | 4.19 | 2 | 2.29 | 1.63 | AMR 8# | |
| 10 | 4.83 | 9.12 | 8.48 | 3.48 | 3.12 | 1.52 | 1.27 | 2.21 | 1.65 | 4.95 | 4.62 | 2 | 2.74 | 2.08 | AMR 10# | |
| 12 | 5.49 | 10.36 | 9.70 | 3.89 | 3.53 | 1.70 | 1.42 | 2.44 | 1.85 | 5.32 | 5.09 | 3 | 2.74 | 2.08 | AMR 12# | |
| 1/4 | 6.35 | 11.99 | 11.25 | 4.44 | 4.06 | 1.90 | 1.63 | 2.77 | 2.08 | 6.81 | 6.48 | 3 | 3.30 | 2.64 | AMR 1/4 | |
| 5/16 | 7.94 | 14.99 | 14.15 | 5.49 | 5.03 | 2.13 | 1.83 | 3.35 | 2.51 | 7.82 | 7.49 | 3 | 4.32 | 3.60 | AMR 5/16 | |
| 3/8 | 9.53 | 17.98 | 17.02 | 6.50 | 6.02 | 2.39 | 2.06 | 3.94 | 2.97 | 9.83 | 9.50 | 4 | 5.28 | 4.82 | AMR 3/8 | |
| 7/16 | 11.11 | 19.05 | 17.95 | 8.33 | 7.80 | 2.39 | 2.06 | 4.95 | 3.76 | 10.21 | 9.88 | 4 | 5.61 | 4.98 | AMR 7/16 | |
| 1/2 | 12.70 | 20.65 | 19.46 | 9.02 | 8.43 | 2.69 | 2.31 | 5.35 | 4.04 | 10.57 | 10.24 | 4 | 5.99 | 5.36 | AMR 1/2 | |
| Nominal Size | Max. | Min. | Max. | Min. | Max. | Min. | Max. | Min. | Max. | Min. | Max. | Min. | # | Max. | Min. | 打字 |
| | A | | H | | J | | T | | M | | Depth | | | | | |

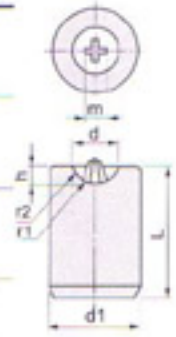

AMP (ANSI PAN HEAD MACHINE & TAPPING SCREW)

| 規格 | 頭部外徑 | | 頭深 | | R | 溝寬 | | 溝深 | | 十字頭深 | | 十字R | 十字寬 | | # | 十字深 | | 打字 | |
|--------------|-------|-------|-------|------|------|------|------|------|------|------|------|------|------|-------|-------|-------|------|------|------------------|
| | 上限 | 下限 | 上限 | 下限 | | 上限 | 下限 | 上限 | 下限 | 上限 | 下限 | | 上限 | 下限 | | 上限 | 下限 | | |
| 0 | 1.52 | 2.95 | 2.64 | 0.99 | 0.79 | 0.51 | 0.58 | 0.41 | 0.56 | 0.36 | 1.12 | 0.91 | 0.13 | 1.70 | 1.37 | 0 | 0.81 | 0.36 | AMP 2# AMP 3# |
| 1 | 1.85 | 3.61 | 3.30 | 1.17 | 0.97 | 0.64 | 0.66 | 0.48 | 0.69 | 0.46 | 1.35 | 1.12 | 0.13 | 1.88 | 1.55 | 0 | 1.02 | 0.56 | |
| 2 | 2.18 | 4.24 | 3.94 | 1.35 | 1.14 | 0.89 | 0.79 | 0.58 | 0.79 | 0.56 | 1.57 | 1.35 | 0.25 | 2.64 | 2.31 | 1 | 1.32 | 0.86 | |
| 3 | 2.51 | 4.90 | 4.57 | 1.52 | 1.30 | 0.94 | 0.89 | 0.69 | 0.91 | 0.66 | 1.80 | 1.57 | 0.25 | 2.84 | 2.51 | 1 | 1.55 | 1.09 | |
| 4 | 2.84 | 5.55 | 5.21 | 1.73 | 1.47 | 1.07 | 0.99 | 0.79 | 1.02 | 0.76 | 2.03 | 1.78 | 0.25 | 3.10 | 2.77 | 1 | 1.80 | 1.35 | AMP 4# |
| 5 | 3.18 | 6.22 | 5.87 | 1.90 | 1.65 | 1.12 | 1.09 | 0.80 | 1.14 | 0.86 | 2.26 | 2.01 | 0.38 | 4.01 | 3.68 | 2 | 1.83 | 1.17 | AMP 5# |
| 6 | 3.51 | 6.86 | 6.50 | 2.08 | 1.83 | 1.17 | 1.22 | 0.99 | 1.27 | 0.94 | 2.46 | 2.21 | 0.38 | 4.22 | 3.89 | 2 | 2.03 | 1.40 | AMP 6# |
| 7 | 3.84 | 7.52 | 7.14 | 2.26 | 2.01 | 1.24 | 1.22 | 0.99 | 1.37 | 1.04 | 2.69 | 2.44 | 0.38 | 4.47 | 4.14 | 2 | 2.26 | 1.63 | AMP 7# |
| 8 | 4.17 | 8.18 | 7.77 | 2.44 | 2.16 | 1.32 | 1.37 | 1.14 | 1.47 | 1.14 | 2.92 | 2.67 | 0.38 | 4.62 | 4.29 | 2 | 2.46 | 1.60 | AMP 8# |
| 10 | 4.83 | 9.47 | 9.07 | 2.79 | 2.51 | 1.55 | 1.52 | 1.27 | 1.73 | 1.35 | 3.38 | 3.10 | 0.51 | 5.05 | 4.72 | 2 | 2.87 | 2.26 | AMP 10# |
| 12 | 5.49 | 10.80 | 10.34 | 3.18 | 2.84 | 1.98 | 1.70 | 1.42 | 1.96 | 1.55 | 3.84 | 3.53 | 0.64 | 6.56 | 6.25 | 3 | 3.15 | 2.49 | AMP 12# |
| 1/4 | 6.35 | 12.50 | 12.01 | 3.66 | 3.30 | 2.21 | 1.90 | 1.63 | 2.21 | 1.78 | 4.44 | 4.11 | 0.89 | 7.14 | 6.81 | 3 | 3.66 | 3.00 | AMP 1/4 |
| 5/16 | 7.94 | 15.62 | 15.09 | 4.52 | 4.11 | 2.51 | 2.13 | 1.83 | 2.89 | 2.16 | 5.54 | 5.16 | 1.02 | 8.89 | 8.56 | 4 | 4.29 | 3.78 | AMP 5/16 |
| 3/8 | 9.53 | 18.80 | 18.19 | 5.38 | 4.95 | 3.63 | 2.39 | 2.06 | 3.15 | 2.54 | 6.83 | 6.20 | 1.02 | 9.88 | 9.55 | 4 | 5.41 | 4.83 | AMP 3/8 |
| 7/16 | 11.11 | 21.92 | 21.26 | 6.27 | 5.79 | 3.89 | 2.39 | 2.06 | 3.61 | 2.95 | 7.75 | 7.21 | 1.27 | 10.49 | 10.16 | 4 | 6.27 | 5.44 | AMP 7/16 |
| 1/2 | 12.70 | 25.07 | 24.33 | 7.14 | 6.60 | 4.44 | 2.69 | 2.31 | 4.09 | 3.33 | 8.84 | 8.25 | 1.40 | 11.05 | 10.72 | 4 | 6.60 | 5.97 | AMP 1/2 |
| Nominal Size | Max. | Min. | Max. | Min. | R | Max. | Min. | Max. | Min. | Max. | Min. | P | Max. | Min. | # | Max. | Min. | 打字 | |
| | A | | H | | | J | | T | | O | | | M | | # | Depth | | | |

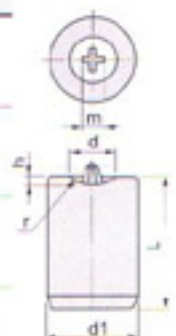

AMT (ANSI TRUSS HEAD MACHINE & TAPPING SCREW)

| 規格 | 頭部外徑 | | 頭深 | | R | 溝寬 | | 溝深 | | 十字寬 | | # | 十字深 | | 打字 | |
|--------------|-------|-------|-------|------|------|-------|------|------|------|------|-------|-------|-------|------|------|----------|
| | 上限 | 下限 | 上限 | 下限 | | 上限 | 下限 | 上限 | 下限 | 上限 | 下限 | | 上限 | 下限 | | |
| 0 | 1.52 | 3.33 | 3.02 | 0.94 | 0.74 | 2.21 | 0.58 | 0.41 | 0.56 | 0.36 | 1.60 | 1.27 | 0 | 0.76 | 0.30 | AMT |
| 1 | 1.85 | 4.17 | 3.78 | 1.14 | 0.94 | 2.72 | 0.66 | 0.48 | 0.69 | 0.46 | 1.80 | 1.47 | 0 | 0.97 | 0.51 | AMT |
| 2 | 2.18 | 4.93 | 4.57 | 1.35 | 1.12 | 3.28 | 0.79 | 0.58 | 0.79 | 0.56 | 2.64 | 2.31 | 1 | 1.32 | 0.56 | AMT 2# |
| 3 | 2.51 | 5.74 | 5.36 | 1.55 | 1.30 | 3.84 | 0.89 | 0.69 | 0.91 | 0.65 | 2.79 | 2.46 | 1 | 1.50 | 1.37 | AMT 3# |
| 4 | 2.84 | 6.53 | 6.12 | 1.75 | 1.50 | 4.29 | 0.99 | 0.79 | 1.02 | 0.75 | 2.84 | 2.51 | 1 | 1.57 | 1.12 | AMT 4# |
| 5 | 3.18 | 7.34 | 6.91 | 1.98 | 1.69 | 4.85 | 1.09 | 0.89 | 1.14 | 0.86 | 3.25 | 2.92 | 1 | 1.98 | 1.32 | AMT 5# |
| 6 | 3.51 | 8.15 | 7.70 | 2.18 | 1.88 | 5.36 | 1.22 | 0.99 | 1.27 | 0.94 | 4.01 | 3.68 | 2 | 1.85 | 1.22 | AMT 6# |
| 7 | 3.84 | 8.94 | 8.46 | 2.39 | 2.06 | 5.87 | 1.22 | 0.99 | 1.37 | 1.04 | 4.19 | 3.86 | 2 | 2.03 | 1.40 | AMT 7# |
| 8 | 4.17 | 9.75 | 9.25 | 2.59 | 2.24 | 6.45 | 1.37 | 1.14 | 1.47 | 1.14 | 4.39 | 4.06 | 2 | 2.24 | 1.60 | AMT 8# |
| 10 | 4.83 | 11.38 | 10.80 | 3.00 | 2.62 | 7.19 | 1.52 | 1.27 | 1.73 | 1.35 | 4.78 | 4.44 | 2 | 2.64 | 2.01 | AMT 10# |
| 12 | 5.49 | 12.98 | 12.37 | 3.40 | 3.00 | 8.53 | 1.70 | 1.42 | 1.96 | 1.55 | 6.30 | 5.97 | 3 | 2.82 | 2.18 | AMT 12# |
| 1/4 | 6.35 | 14.55 | 13.87 | 3.81 | 3.38 | 9.53 | 1.90 | 1.63 | 2.21 | 1.78 | 6.68 | 6.35 | 3 | 3.20 | 2.57 | AMT 1/4 |
| 5/16 | 7.94 | 17.73 | 16.92 | 4.65 | 4.11 | 11.61 | 2.13 | 1.83 | 2.69 | 2.16 | 8.94 | 8.61 | 4 | 4.39 | 3.76 | AMT 5/16 |
| 3/8 | 9.53 | 20.90 | 19.99 | 5.46 | 4.85 | 13.67 | 2.39 | 2.06 | 3.15 | 2.54 | 9.73 | 9.40 | 4 | 5.23 | 4.52 | AMT 3/8 |
| 7/16 | 11.11 | 24.08 | 23.04 | 6.30 | 5.61 | 15.72 | 2.39 | 2.06 | 3.61 | 2.95 | 10.52 | 10.19 | 4 | 6.02 | 5.38 | AMT 7/16 |
| 1/2 | 12.70 | 27.25 | 25.11 | 7.11 | 6.35 | 17.81 | 2.69 | 2.31 | 4.09 | 3.33 | 11.28 | 10.95 | 4 | 6.81 | 6.17 | AMT 1/2 |
| Nominal Size | Max | Min | Max | Min | R | Max | Min | Max | Min | Max | Min | # | Max | Min | 打字 | |
| | A | | H | | | J | | T | | M | | | Depth | | | |

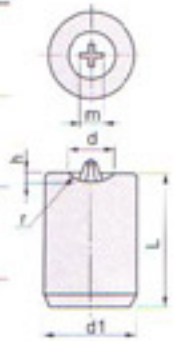

AML (ANSI FILLISTER HEAD MACHINE & TAPPING SCREW)

| 規格 | 頭部外徑 | | H | | 頭深 | | 溝寬 | | 溝深 | | 十字寬 | | # | 十字深 | | 打字 | |
|--------------|-------|-------|-------|------|------|-------|-------|------|------|------|------|-------|-------|-------|------|------|----------|
| | 上限 | 下限 | 上限 | 下限 | 上限 | 下限 | 上限 | 下限 | 上限 | 下限 | 上限 | 下限 | | 上限 | 下限 | | |
| 0 | 1.52 | 2.44 | 2.11 | 1.09 | 0.97 | 1.40 | 1.19 | 0.58 | 0.41 | 0.64 | 0.38 | 1.70 | 1.37 | 0 | 0.81 | 0.36 | AML |
| 1 | 1.85 | 3.00 | 2.64 | 1.35 | 1.14 | 1.68 | 1.47 | 0.58 | 0.48 | 0.79 | 0.51 | 1.88 | 1.55 | 0 | 1.02 | 0.56 | AML |
| 2 | 2.18 | 3.56 | 3.15 | 1.57 | 1.35 | 2.11 | 1.68 | 0.79 | 0.58 | 0.94 | 0.64 | 2.64 | 2.31 | 1 | 1.32 | 0.86 | AML 2# |
| 3 | 2.51 | 4.09 | 3.68 | 1.78 | 1.55 | 2.41 | 1.96 | 0.89 | 0.69 | 1.09 | 0.76 | 2.84 | 2.51 | 1 | 1.55 | 1.09 | AML 3# |
| 4 | 2.84 | 4.65 | 4.22 | 2.01 | 1.75 | 2.72 | 2.24 | 0.99 | 0.79 | 1.22 | 0.89 | 3.10 | 2.77 | 1 | 1.80 | 1.35 | AML 4# |
| 5 | 3.18 | 5.21 | 4.75 | 2.24 | 1.98 | 3.05 | 2.54 | 1.09 | 0.89 | 1.37 | 1.02 | 3.63 | 3.30 | 1 | 1.42 | 1.12 | AML 5# |
| 6 | 3.51 | 5.74 | 5.28 | 2.44 | 2.18 | 3.35 | 2.82 | 1.22 | 0.99 | 1.52 | 1.14 | 4.22 | 3.89 | 2 | 2.03 | 1.40 | AML 6# |
| 7 | 3.84 | 6.30 | 5.82 | 2.67 | 2.39 | 3.66 | 3.10 | 1.22 | 0.99 | 1.65 | 1.24 | 4.47 | 4.14 | 2 | 2.25 | 1.63 | AML 7# |
| 8 | 4.17 | 6.86 | 6.35 | 2.87 | 2.59 | 3.96 | 3.38 | 1.37 | 1.14 | 1.86 | 1.37 | 4.62 | 4.29 | 2 | 2.45 | 1.80 | AML 8# |
| 10 | 4.83 | 7.95 | 7.42 | 3.30 | 3.00 | 4.57 | 3.96 | 1.52 | 1.27 | 2.11 | 1.63 | 5.05 | 4.72 | 2 | 2.87 | 2.26 | AML 10# |
| 12 | 5.49 | 9.07 | 8.48 | 3.76 | 3.40 | 5.21 | 4.52 | 1.70 | 1.42 | 2.39 | 1.88 | 6.58 | 6.25 | 3 | 3.15 | 2.49 | AML 12# |
| 1/4 | 6.35 | 10.52 | 9.88 | 4.32 | 3.94 | 6.02 | 5.26 | 1.90 | 1.63 | 2.77 | 2.21 | 7.14 | 6.81 | 3 | 3.60 | 3.00 | AML 1/4 |
| 5/16 | 7.94 | 13.16 | 12.45 | 5.36 | 4.93 | 7.49 | 6.65 | 2.13 | 1.83 | 3.48 | 2.79 | 8.18 | 7.85 | 3 | 4.72 | 4.06 | AML 5/16 |
| 3/8 | 9.53 | 15.80 | 14.99 | 6.43 | 5.92 | 9.02 | 8.00 | 2.39 | 2.06 | 4.17 | 3.36 | 9.88 | 9.55 | 4 | 5.41 | 4.83 | AML 3/8 |
| 7/16 | 11.11 | 18.88 | 18.06 | 7.73 | 7.15 | 10.95 | 9.85 | 2.59 | 2.26 | 4.82 | 3.43 | 10.49 | 10.16 | 4 | 6.07 | 5.44 | AML 7/16 |
| 1/2 | 12.70 | 21.95 | 21.03 | 9.14 | 8.53 | 12.98 | 11.81 | 2.89 | 2.51 | 5.61 | 4.03 | 11.55 | 11.22 | 4 | 6.81 | 6.17 | AML 1/2 |
| Nominal Size | Max | Min | Max | Min | Max | Min | Max | Min | Max | Min | Max | Min | # | Max | Min | 打字 | |
| | A | | H | | C | | J | | T | | M | | | Depth | | | |

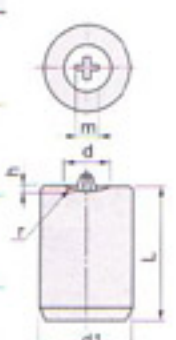

AMB (ANSI BINDING HEAD MACHINE & TAPPING SCREW)

| 規格 | 頭部外徑 | | 頭深 | | R深 | | 溝寬 | | 溝深 | | R寬 | | X | | 十字寬 | | # | 十字深 | | 打字 | |
|--|--|---|--|--|--|--|--|--|--|--|--|---|--|--|--|---|--|--------------------------------------|--|--|--|
| | 上限 | 下限 | 上限 | 下限 | 上限 | 下限 | 上限 | 下限 | 上限 | 下限 | 上限 | 下限 | 上限 | 下限 | 上限 | 下限 | | 上限 | 下限 | | |
| 0000 000 00 0 | 0.53 0.86 1.19 1.52 | 1.02 1.70 2.29 3.02 | 0.36 0.53 0.71 0.81 | 0.23 0.38 0.58 0.66 | 0.15 0.20 0.28 0.30 | 0.08 0.13 0.18 0.20 | 0.20 0.30 0.43 0.58 | 0.10 0.15 0.25 0.41 | 0.10 0.15 0.25 0.41 | 0.23 0.33 0.46 0.62 | 0.13 0.23 0.30 0.46 | — — — — | — — — — | — — — — | — — — — | — — — — | — — — — | — — — — | — — — — | — — — — | — — — — |
| 1 2 3 4 | 1.85 2.18 2.51 2.84 | 3.89 4.60 5.28 5.97 | 3.60 4.34 5.00 5.66 | 1.04 1.29 1.50 1.73 | 0.89 1.09 1.32 1.55 | 0.38 0.46 0.56 0.64 | 0.28 0.33 0.41 0.46 | 0.68 0.79 0.89 0.99 | 0.48 0.58 0.69 0.79 | 0.61 0.76 0.91 1.07 | 0.38 0.51 0.64 0.76 | 3.05 3.58 4.11 4.67 | 2.87 3.15 3.83 4.09 | 0.20 0.25 0.28 0.30 | 0.68 0.88 1.15 1.37 | 1.88 2.21 2.79 3.00 | 1.55 2.21 2.46 2.67 | 0 1 1 1 | 1.02 1.55 1.78 | 0.58 1.12 1.32 | AMB 2# AMB 3# AMB 4# |
| 5 6 8 10 12 14 5/16 3/8 | 3.18 3.51 4.17 4.83 5.49 6.35 7.94 9.53 | 6.88 7.37 8.74 10.13 11.53 13.34 16.66 20.02 | 6.32 6.99 8.23 9.60 10.92 12.65 15.80 18.95 | 1.98 2.21 2.41 2.84 3.58 4.19 5.31 6.43 | 1.75 1.98 2.21 2.84 3.30 3.86 4.93 5.97 | 0.74 0.81 0.90 1.14 1.32 1.55 1.96 2.39 | 0.53 0.61 0.74 1.06 1.22 1.32 1.50 1.80 | 1.09 1.22 1.37 1.52 1.79 1.93 2.13 2.39 | 0.89 0.99 1.14 1.27 1.42 1.63 1.83 2.06 | 1.22 1.35 1.65 1.96 2.26 2.67 3.40 4.14 | 0.89 1.02 1.27 1.52 1.73 2.13 2.74 3.35 | 5.21 5.74 6.83 7.92 8.99 10.41 13.03 15.62 | 4.57 5.05 5.99 6.96 7.90 9.14 11.43 13.72 | 0.36 0.38 0.43 0.51 0.58 0.66 0.81 0.99 | 0.23 0.25 0.30 0.38 0.46 0.53 0.69 0.86 | 3.70 4.06 4.72 5.21 6.78 7.14 8.89 10.10 | 3.43 3.73 4.39 4.88 6.45 6.81 8.56 9.83 | 2 2 2 2 3 3 4 4 | 1.63 1.96 2.62 3.12 3.40 3.73 4.44 5.77 | 1.02 1.35 2.01 2.49 2.77 3.12 3.86 5.16 | AMB 5# AMB 6# AMB 8# AMB 10# AMB 12# AMB 1/4 AMB 5/16 AMB 3/8 |
| Nominal Size | Max. | Min. | Max. | Min. | Max. | Min. | Max. | Min. | Max. | Min. | Max. | Min. | Max. | Min. | Max. | Min. | # | Max. | Min. | 打字 | |
| | A | | O | | F | | J | | T | | U | | X | | M | | # | Depth | | 打字 | |



ATF (ANSI FLAT HEAD TAPPING SCREW)

| 規格 | 頭部外徑 | | | 頭深 | F | | 溝寬 | | 溝深 | | 十字寬 | | # | 十字深 | | 打字 | |
|----------------------------|---|---|---|---|--------------------------------------|--------------------------------------|--------------------------------------|--------------------------------------|--------------------------------------|--------------------------------------|--------------------------------------|--------------------------------------|--------------------------------------|-----------------------|--------------------------------------|--------------------------------------|---|
| | 上限 | 下限 | Abs. | | 上限 | 下限 | 上限 | 下限 | 上限 | 下限 | 上限 | 下限 | | 上限 | 下限 | | |
| 14 16 18 20 24 | 12.47 13.82 15.15 16.51 19.20 | 11.71 13.00 14.30 15.60 18.19 | 11.10 12.32 13.56 14.78 17.25 | 10.41 11.61 12.83 14.05 16.46 | 1.24 1.32 1.40 1.47 1.65 | 0.74 0.79 0.84 0.89 0.99 | 3.75 4.17 4.57 4.98 5.79 | 1.90 1.90 1.83 2.13 2.39 | 1.63 1.63 1.83 1.83 2.06 | 1.73 1.90 2.11 2.29 2.67 | 1.12 1.24 1.37 1.50 1.75 | 7.19 7.70 9.27 9.60 9.66 | 6.86 7.37 8.94 9.27 9.65 | 3 3 4 4 4 | 3.91 4.42 4.98 5.33 5.72 | 3.33 3.84 4.42 4.78 5.16 | ATF 14# ATF 16# ATF 18# ATF 20# ATF 24# |
| Nominal Size | Max. | Min. | Abs. | G | Max. | Min. | H | Max. | Min. | Max. | Min. | Max. | Min. | # | Max. | Min. | 打字 |
| | A | | | G | F | | H | J | | T | | M | | # | Depth | | 打字 |

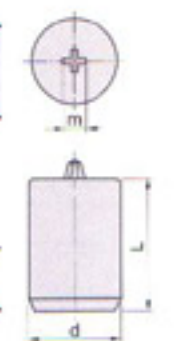

ATAO (ANSI OVAL HEAD TAPPING SCREW)

| 規格 | 頭部外徑 | | | 頭深 | 頭深 | | 溝寬 | | 溝深 | | 十字寬 | | # | 十字深 | | 打字 |
|----------------------------|---|---|---|--------------------------------------|--------------------------------------|--------------------------------------|--------------------------------------|--------------------------------------|--------------------------------------|--------------------------------------|--|---------------------------------------|-----------------------|--------------------------------------|--------------------------------------|--|
| | 上限 | 下限 | Abs. | | 上限 | 下限 | 上限 | 下限 | 上限 | 下限 | 上限 | 下限 | | 上限 | 下限 | |
| 14 16 18 20 24 | 12.47 13.82 15.15 16.51 19.20 | 11.71 13.00 14.30 15.60 18.19 | 11.10 12.32 13.56 14.78 17.25 | 3.76 4.17 4.57 4.98 5.79 | 5.69 6.30 6.91 7.52 8.74 | 4.83 5.38 5.92 6.45 7.54 | 1.90 1.90 2.13 2.13 2.39 | 1.63 1.63 1.83 1.83 2.06 | 3.35 3.71 4.06 4.44 5.18 | 2.74 3.05 3.35 3.66 4.27 | 7.32 8.43 9.66 10.16 11.07 | 6.99 8.10 9.35 9.83 10.74 | 3 3 4 4 4 | 3.75 5.00 5.23 5.72 6.65 | 3.12 4.37 4.62 5.11 6.05 | ATAO 14# ATAO 16# ATAO 18# ATAO 20# ATAO 24# |
| Nominal Size | Max. | Min. | Abs. | H | Max. | Min. | Max. | Min. | Max. | Min. | Max. | Min. | # | Max. | Min. | 打字 |
| | A | | | H | O | | J | | T | | M | | # | Depth | | 打字 |

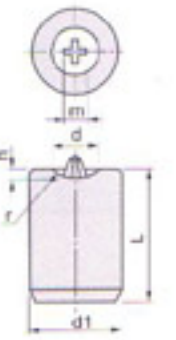

ATAT (ANSI TRUSS HEAD TAPPING SCREW)

| 規格 | 頭部外徑 | | 頭深 | | 溝寬 | | 溝深 | | R | 十字寬 | | # | 十字深 | | 打字 |
|--------------|-------|-------|------|------|------|------|------|------|-------|------|------|---|-------|------|----------|
| | 上限 | 下限 | 上限 | 下限 | 上限 | 下限 | 上限 | 下限 | | 上限 | 下限 | | 上限 | 下限 | |
| 14 | 14.15 | 13.46 | 3.71 | 3.26 | 1.90 | 1.63 | 2.16 | 1.73 | 9.53 | 6.68 | 6.35 | 3 | 3.20 | 2.57 | ATAT 14# |
| 16 | 15.47 | 14.73 | 4.04 | 3.58 | 1.90 | 1.63 | 2.36 | 1.88 | 10.41 | 6.78 | 6.45 | 3 | 3.40 | 2.77 | ATAT 16# |
| 18 | 16.79 | 16.00 | 4.39 | 3.89 | 2.13 | 1.83 | 2.54 | 2.03 | 11.33 | 8.20 | 7.87 | 4 | 3.65 | 3.07 | ATAT 18# |
| 20 | 18.11 | 17.27 | 4.72 | 4.19 | 2.13 | 1.83 | 2.74 | 2.21 | 12.29 | 9.04 | 8.71 | 4 | 4.50 | 3.84 | ATAT 20# |
| 24 | 20.75 | 19.81 | 5.41 | 4.83 | 2.39 | 2.06 | 3.12 | 2.54 | 14.15 | 9.86 | 9.53 | 4 | 5.66 | 4.93 | ATAT 24# |
| Nominal Size | Max. | Min. | Max. | Min. | Max. | Min. | Max. | Min. | R | Max. | Min. | # | Max. | Min. | 打字 |
| | A | | H | | J | | T | | | M | | | Depth | | |

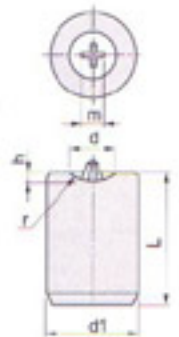

ATAR (ANSI ROUND HEAD TAPPING SCREW)

| 規格 | 頭部外徑 | | 頭深 | | 溝寬 | | 溝深 | | 十字寬 | | # | 十字深 | | 打字 |
|--------------|-------|-------|------|------|------|------|------|------|------|------|---|-------|------|----------|
| | 上限 | 下限 | 上限 | 下限 | 上限 | 下限 | 上限 | 下限 | 上限 | 下限 | | 上限 | 下限 | |
| 14 | 11.61 | 10.90 | 4.32 | 3.94 | 1.90 | 1.53 | 2.69 | 2.03 | 5.73 | 6.40 | 3 | 3.18 | 2.51 | ATAR 14# |
| 16 | 12.85 | 12.09 | 4.75 | 4.34 | 1.90 | 1.53 | 2.92 | 2.21 | 7.14 | 6.81 | 3 | 3.61 | 3.02 | ATAR 16# |
| 18 | 14.10 | 13.28 | 5.18 | 4.75 | 2.13 | 1.83 | 3.18 | 2.39 | 8.36 | 8.03 | 4 | 3.73 | 3.07 | ATAR 18# |
| 20 | 15.34 | 14.48 | 5.59 | 5.10 | 2.13 | 1.83 | 3.40 | 2.57 | 9.74 | 8.41 | 4 | 4.14 | 3.48 | ATAR 20# |
| 24 | 17.83 | 16.87 | 6.45 | 5.97 | 2.39 | 2.06 | 3.91 | 2.95 | 9.83 | 9.05 | 4 | 5.29 | 4.62 | ATAR 24# |
| Nominal Size | Max. | Min. | Max. | Min. | Max. | Min. | Max. | Min. | Max. | Min. | # | Max. | Min. | 打字 |
| | A | | H | | J | | T | | M | | | Depth | | |

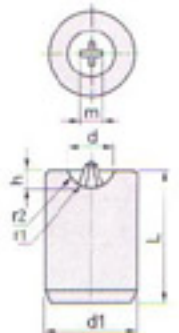
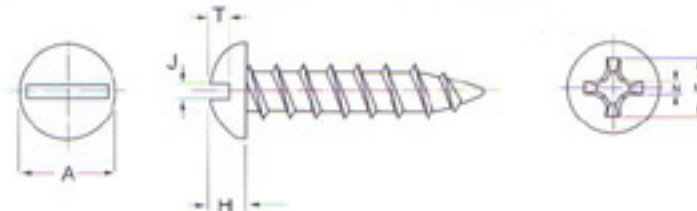

ATAP (ANSI PAN HEAD TAPPING SCREW)

| 規格 | 頭部外徑 | | 頭深 | | 溝寬 | | 溝深 | | R | 十字頭深 | | 十字寬 | | # | 十字深 | | 打字 |
|--------------|-------|-------|------|------|------|------|------|------|------|------|------|------|------|---|-------|------|----------|
| | 上限 | 下限 | 上限 | 下限 | 上限 | 下限 | 上限 | 下限 | | 上限 | 下限 | 上限 | 下限 | | 上限 | 下限 | |
| 14 | 12.09 | 11.61 | 3.53 | 3.20 | 1.90 | 1.63 | 2.16 | 1.73 | 2.21 | 4.29 | 3.96 | 7.14 | 6.81 | 3 | 3.00 | 3.00 | ATAP 14# |
| 16 | 13.41 | 12.90 | 3.89 | 3.53 | 1.88 | 1.63 | 2.36 | 1.78 | 2.39 | 4.75 | 4.39 | 7.42 | 7.09 | 3 | 4.01 | 3.35 | ATAP 16# |
| 18 | 14.71 | 14.17 | 4.27 | 3.89 | 2.13 | 1.83 | 2.54 | 2.03 | 2.51 | 5.21 | 4.85 | 8.51 | 8.18 | 4 | 4.01 | 3.40 | ATAP 18# |
| 20 | 16.03 | 15.44 | 4.62 | 4.22 | 2.13 | 1.83 | 2.74 | 2.21 | 3.07 | 5.66 | 5.28 | 8.89 | 8.56 | 4 | 4.39 | 3.78 | ATAP 20# |
| 24 | 18.64 | 18.01 | 5.36 | 4.90 | 2.39 | 2.06 | 3.12 | 2.54 | 3.63 | 6.58 | 6.15 | 9.98 | 9.65 | 4 | 5.41 | 4.83 | ATAP 24# |
| Nominal Size | Max. | Min. | Max. | Min. | Max. | Min. | Max. | Min. | R | Max. | Min. | Max. | Min. | # | Max. | Min. | 打字 |
| | A | | H | | J | | T | | | F | | M | | | Depth | | |

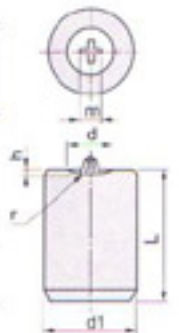

AWO (ANSI OVAL HEAD WOOD SCREW)

| 規格 | TPI | 杆徑 | | 頭部外徑 | | 頭深 | | 溝寬 | | 溝深 | | R | 十字寬 | | # | 十字深 | | 打字 | | |
|--------------|------|------|------|------|-------|-------|------|------|------|------|------|------|------|------|-------|-------|------|------|-------|---|
| | | 上限 | 下限 | 上限 | 下限 | 上限 | 下限 | 上限 | 下限 | 上限 | 下限 | | 上限 | 下限 | | 上限 | 下限 | | | |
| | | E | | A | | H | | O | | J | | | T | | | M | | | Depth | |
| 0 | 1.52 | 32 | 1.63 | 1.35 | 3.62 | 2.51 | 0.89 | 1.42 | 1.04 | 0.58 | 0.41 | 0.76 | 0.64 | 0.79 | 1.38 | 1.55 | 0 | 0.97 | 0.51 | AWO 2# AWO 3# |
| 1 | 1.85 | 28 | 1.96 | 1.58 | 3.71 | 3.12 | 1.09 | 1.73 | 1.32 | 0.66 | 0.48 | 0.97 | 0.79 | 0.79 | 1.30 | 1.63 | 0 | 1.04 | 0.58 | |
| 2 | 2.18 | 26 | 2.29 | 2.01 | 4.37 | 3.73 | 1.30 | 2.03 | 1.60 | 0.79 | 0.58 | 1.14 | 0.94 | 0.79 | 2.34 | 2.51 | 1 | 1.57 | 1.14 | |
| 3 | 2.51 | 24 | 2.62 | 2.34 | 5.05 | 4.34 | 1.50 | 2.34 | 1.85 | 0.89 | 0.69 | 1.32 | 1.09 | 0.79 | 3.15 | 2.82 | 1 | 1.88 | 1.45 | |
| 4 | 2.84 | 22 | 2.95 | 2.67 | 5.72 | 4.95 | 1.70 | 2.64 | 2.13 | 0.99 | 0.79 | 1.50 | 1.24 | 0.79 | 3.45 | 3.12 | 1 | 2.21 | 1.78 | AWO 4# AWO 5# AWO 6# AWO 7# |
| 5 | 3.18 | 20 | 3.28 | 3.00 | 6.40 | 5.59 | 1.90 | 2.95 | 2.41 | 1.09 | 0.89 | 1.70 | 1.40 | 1.57 | 4.31 | 3.68 | 2 | 1.88 | 1.27 | |
| 6 | 3.51 | 18 | 3.61 | 3.33 | 7.09 | 6.20 | 2.11 | 3.25 | 2.67 | 1.22 | 0.99 | 1.88 | 1.52 | 1.57 | 4.52 | 4.19 | 2 | 2.39 | 1.75 | |
| 7 | 3.84 | 16 | 3.94 | 3.66 | 7.76 | 6.81 | 2.31 | 3.56 | 2.95 | 1.22 | 0.99 | 2.06 | 1.68 | 1.57 | 4.80 | 4.47 | 2 | 2.64 | 2.06 | |
| 8 | 4.17 | 15 | 4.27 | 3.99 | 8.43 | 7.42 | 2.54 | 3.86 | 3.20 | 1.37 | 1.14 | 2.24 | 1.83 | 1.57 | 5.21 | 4.88 | 2 | 3.05 | 2.41 | AWO 8# AWO 9# AWO 10# AWO 12# |
| 9 | 4.50 | 14 | 4.60 | 4.32 | 9.09 | 8.03 | 2.74 | 4.17 | 3.48 | 1.37 | 1.14 | 2.41 | 1.98 | 1.57 | 5.49 | 5.16 | 2 | 3.38 | 2.74 | |
| 10 | 4.83 | 13 | 4.93 | 4.65 | 9.78 | 8.64 | 2.90 | 4.47 | 3.76 | 1.52 | 1.27 | 2.62 | 2.13 | 1.57 | 6.03 | 6.30 | 3 | 3.18 | 2.57 | |
| 12 | 5.49 | 11 | 5.59 | 5.31 | 11.13 | 9.88 | 3.35 | 5.08 | 4.29 | 1.70 | 1.42 | 2.97 | 2.44 | 1.57 | 7.19 | 6.86 | 3 | 3.76 | 3.12 | |
| 14 | 6.15 | 10 | 6.25 | 5.97 | 12.47 | 11.10 | 3.76 | 5.69 | 4.83 | 1.90 | 1.63 | 3.35 | 2.74 | 2.36 | 7.75 | 7.42 | 3 | 4.34 | 3.71 | AWO 14# AWO 16# AWO 18# AWO 20# AWO 24# |
| 16 | 6.81 | 9 | 6.91 | 6.63 | 13.82 | 12.32 | 4.17 | 6.30 | 5.36 | 1.90 | 1.63 | 3.71 | 3.05 | 2.36 | 8.43 | 8.10 | 3 | 5.00 | 4.37 | |
| 18 | 7.47 | 8 | 7.57 | 7.29 | 15.16 | 13.56 | 4.57 | 6.91 | 5.92 | 2.13 | 1.83 | 4.06 | 3.35 | 2.36 | 9.68 | 9.35 | 4 | 5.23 | 4.62 | |
| 20 | 8.13 | 8 | 8.23 | 7.95 | 16.51 | 14.78 | 4.98 | 7.52 | 6.45 | 2.13 | 1.83 | 4.44 | 3.66 | 2.36 | 10.96 | 9.83 | 4 | 5.72 | 5.11 | |
| 24 | 9.45 | 7 | 9.55 | 9.27 | 19.20 | 17.25 | 5.79 | 8.74 | 7.54 | 2.39 | 2.06 | 5.18 | 4.27 | 2.36 | 11.07 | 10.74 | 4 | 6.65 | 6.05 | |
| Nominal Size | TPI | Max. | Min. | Max. | Min. | Max. | Min. | Max. | Min. | Max. | Min. | Max. | Min. | Max. | Min. | # | Max. | Min. | Depth | 打字 |

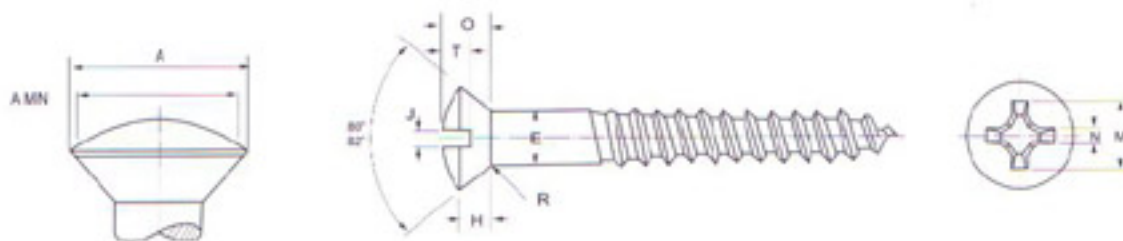
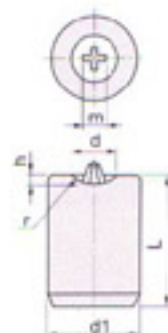

AWR (ANSI ROUND HEAD WOOD SCREW)

| 規格 | TPI | 杆徑 | | 頭部外徑 | | 頭深 | | 溝寬 | | 溝深 | | R | 十字寬 | | # | 十字深 | | 打字 | | |
|--------------|------|------|------|------|-------|-------|------|------|------|------|------|------|------|------|------|-------|------|------|---|----|
| | | 上限 | 下限 | 上限 | 下限 | 上限 | 下限 | 上限 | 下限 | 上限 | 下限 | | 上限 | 下限 | | | | | | |
| | | E | | A | | H | | J | | T | | | M | | | Depth | | | | |
| 0 | 1.52 | 32 | 1.63 | 1.35 | 2.87 | 2.51 | 1.35 | 1.09 | 0.58 | 0.41 | 0.99 | 0.74 | 0.41 | 1.85 | 1.52 | 0 | 0.89 | 0.38 | AWR 2# AWR 3# | |
| 1 | 1.85 | 28 | 1.96 | 1.68 | 3.15 | 3.10 | 1.55 | 1.30 | 0.66 | 0.48 | 1.12 | 0.84 | 0.41 | 2.08 | 1.75 | 0 | 1.14 | 0.66 | | |
| 2 | 2.18 | 26 | 2.29 | 2.01 | 4.11 | 3.71 | 1.75 | 1.50 | 0.75 | 0.58 | 1.22 | 0.94 | 0.41 | 2.90 | 2.57 | 1 | 1.45 | 0.89 | | |
| 3 | 2.51 | 24 | 2.62 | 2.34 | 4.75 | 4.29 | 1.98 | 1.70 | 0.88 | 0.69 | 1.35 | 1.02 | 0.41 | 3.10 | 2.77 | 1 | 1.68 | 1.14 | | |
| 4 | 2.84 | 22 | 2.95 | 2.67 | 5.36 | 4.90 | 2.18 | 1.90 | 0.99 | 0.79 | 1.47 | 1.12 | 0.41 | 3.30 | 2.97 | 1 | 1.93 | 1.42 | AWR 4# AWR 5# AWR 6# AWR 7# | |
| 5 | 3.18 | 20 | 3.28 | 3.00 | 5.99 | 5.51 | 2.41 | 2.11 | 1.09 | 0.89 | 1.60 | 1.19 | 0.79 | 3.91 | 3.58 | 2 | 1.60 | 0.89 | | |
| 6 | 3.51 | 18 | 3.61 | 3.33 | 6.60 | 6.10 | 2.62 | 2.41 | 1.22 | 0.99 | 1.73 | 1.30 | 0.79 | 4.11 | 3.78 | 2 | 1.85 | 1.14 | | |
| 7 | 3.84 | 16 | 3.94 | 3.66 | 7.24 | 6.71 | 2.82 | 2.51 | 1.22 | 0.99 | 1.83 | 1.40 | 0.79 | 4.32 | 3.99 | 2 | 2.06 | 1.40 | | |
| 8 | 4.17 | 15 | 4.27 | 3.99 | 7.85 | 7.29 | 3.05 | 2.72 | 1.37 | 1.14 | 1.90 | 1.47 | 0.79 | 4.52 | 4.19 | 2 | 2.29 | 1.63 | AWR 8# AWR 9# AWR 10# AWR 12# | |
| 9 | 4.50 | 14 | 4.60 | 4.32 | 8.48 | 7.90 | 3.25 | 2.92 | 1.37 | 1.14 | 2.08 | 1.57 | 0.79 | 4.72 | 4.39 | 2 | 2.51 | 1.85 | | |
| 10 | 4.83 | 13 | 4.93 | 4.65 | 9.12 | 8.48 | 3.48 | 3.12 | 1.52 | 1.27 | 2.21 | 1.65 | 0.79 | 4.95 | 4.62 | 2 | 2.74 | 2.08 | | |
| 12 | 5.49 | 11 | 5.59 | 5.31 | 10.36 | 9.70 | 3.89 | 3.53 | 1.70 | 1.42 | 2.44 | 1.85 | 0.79 | 6.32 | 5.99 | 3 | 2.74 | 2.08 | | |
| 14 | 6.15 | 10 | 6.25 | 5.97 | 11.61 | 10.90 | 4.32 | 3.94 | 1.90 | 1.63 | 2.69 | 2.03 | 1.17 | 6.73 | 6.40 | 3 | 3.18 | 2.51 | AWR 14# AWR 16# AWR 18# AWR 20# AWR 24# | |
| 16 | 6.81 | 9 | 6.91 | 6.63 | 12.85 | 12.09 | 4.75 | 4.34 | 1.90 | 1.63 | 2.92 | 2.21 | 1.17 | 7.14 | 6.81 | 3 | 3.61 | 3.02 | | |
| 18 | 7.47 | 8 | 7.57 | 7.29 | 14.10 | 13.28 | 5.18 | 4.75 | 2.13 | 1.83 | 3.18 | 2.39 | 1.17 | 8.61 | 8.28 | 4 | 3.95 | 3.33 | | |
| 20 | 8.13 | 8 | 8.23 | 7.95 | 15.34 | 14.48 | 5.59 | 5.16 | 2.13 | 1.83 | 3.40 | 2.57 | 1.17 | 9.04 | 8.71 | 4 | 4.42 | 3.76 | | |
| 24 | 9.45 | 7 | 9.55 | 9.27 | 17.83 | 16.67 | 6.45 | 5.97 | 2.39 | 2.06 | 3.91 | 2.95 | 1.17 | 9.83 | 9.50 | 4 | 5.28 | 4.62 | | |
| Nominal Size | TPI | Max. | Min. | Max. | Min. | Max. | Min. | Max. | Min. | Max. | Min. | Max. | Min. | Max. | Min. | # | Max. | Min. | Depth | 打字 |

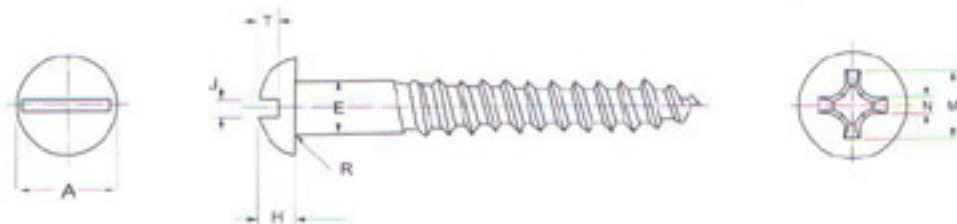
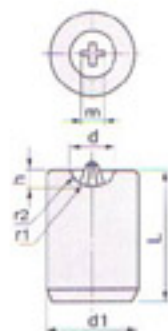

AWF (ANSI FLAT HEAD WOOD SCREW)

| 規格 | TPI | 杆徑 | | 頭部外徑 | | 頭深 | 溝寬 | | 溝深 | | R | 十字寬 | | # | 十字深 | | 打字 | | |
|--------------|------|------|------|------|-------|-------|------|------|------|------|------|------|-------|-------|-----|------|------|------------------|----|
| | | 上限 | 下限 | 上限 | 下限 | | 上限 | 下限 | 上限 | 下限 | | 上限 | 下限 | | 上限 | 下限 | | | |
| | | E | | A | | | H | | J | | | T | | | M | | | Depth | |
| 0 | 1.52 | 32 | 1.63 | 1.35 | 3.02 | 2.51 | 0.89 | 0.58 | 0.41 | 0.38 | 0.25 | 0.79 | 1.75 | 1.42 | 0 | 0.91 | 0.51 | AWF 2# AWF 3# | |
| 1 | 1.85 | 28 | 1.96 | 1.68 | 3.71 | 3.12 | 1.09 | 0.66 | 0.48 | 0.46 | 0.30 | 0.79 | 1.90 | 1.63 | 0 | 1.12 | 0.71 | | |
| 2 | 2.18 | 26 | 2.29 | 2.01 | 4.37 | 3.73 | 1.30 | 0.79 | 0.58 | 0.58 | 0.38 | 0.79 | 2.59 | 2.26 | 1 | 1.42 | 1.02 | | |
| 3 | 2.51 | 24 | 2.62 | 2.34 | 5.05 | 4.34 | 1.50 | 0.89 | 0.69 | 0.69 | 0.43 | 0.79 | 2.72 | 2.39 | 1 | 1.55 | 1.14 | | |
| 4 | 2.84 | 22 | 2.95 | 2.67 | 5.72 | 4.95 | 1.70 | 0.99 | 0.79 | 0.76 | 0.51 | 0.79 | 3.25 | 2.92 | 1 | 2.08 | 1.68 | AWF 4# | |
| 5 | 3.18 | 20 | 3.28 | 3.00 | 6.40 | 5.59 | 1.90 | 1.09 | 0.89 | 0.86 | 0.56 | 1.57 | 3.91 | 3.58 | 2 | 1.90 | 1.32 | AWF 5# | |
| 6 | 3.51 | 18 | 3.61 | 3.33 | 7.09 | 6.20 | 2.11 | 1.22 | 0.99 | 0.97 | 0.61 | 1.57 | 4.42 | 4.09 | 2 | 2.41 | 1.83 | AWF 6# | |
| 7 | 3.84 | 16 | 3.94 | 3.66 | 7.75 | 6.81 | 2.31 | 1.22 | 0.99 | 1.04 | 0.69 | 1.57 | 4.80 | 4.47 | 2 | 2.79 | 2.21 | AWF 7# | |
| 8 | 4.17 | 15 | 4.27 | 3.99 | 8.43 | 7.42 | 2.54 | 1.37 | 1.14 | 1.14 | 0.74 | 1.57 | 5.18 | 4.85 | 2 | 3.18 | 2.50 | AWF 8# | |
| 9 | 4.50 | 14 | 4.60 | 4.32 | 9.09 | 8.03 | 2.74 | 1.37 | 1.14 | 1.24 | 0.81 | 1.57 | 5.44 | 5.11 | 2 | 3.43 | 2.84 | AWF 9# | |
| 10 | 4.83 | 13 | 4.93 | 4.65 | 9.78 | 8.64 | 2.95 | 1.52 | 1.27 | 1.35 | 0.86 | 1.57 | 6.55 | 6.22 | 3 | 3.28 | 2.69 | AWF 10# | |
| 12 | 5.49 | 11 | 5.59 | 5.31 | 11.13 | 9.88 | 3.35 | 1.70 | 1.42 | 1.52 | 0.99 | 1.57 | 7.19 | 6.86 | 3 | 3.91 | 3.33 | AWF 12# | |
| 14 | 6.15 | 10 | 6.25 | 5.97 | 12.47 | 11.10 | 3.76 | 1.90 | 1.63 | 1.73 | 1.12 | 2.36 | 7.70 | 7.37 | 3 | 4.42 | 3.84 | AWF 14# | |
| 16 | 6.81 | 9 | 6.91 | 6.63 | 13.82 | 12.32 | 4.17 | 1.90 | 1.63 | 1.90 | 1.24 | 2.36 | 8.31 | 7.98 | 3 | 5.05 | 4.47 | AWF 16# | |
| 18 | 7.47 | 8 | 7.57 | 7.29 | 15.16 | 13.56 | 4.57 | 2.13 | 1.83 | 2.11 | 1.37 | 2.36 | 9.90 | 9.27 | 4 | 5.33 | 4.78 | AWF 18# | |
| 20 | 8.13 | 8 | 8.23 | 7.95 | 16.51 | 14.78 | 4.98 | 2.13 | 1.83 | 2.29 | 1.50 | 2.36 | 9.98 | 9.65 | 4 | 5.72 | 5.16 | AWF 20# | |
| 24 | 9.45 | 7 | 9.55 | 9.27 | 19.20 | 17.25 | 5.79 | 2.39 | 2.06 | 2.67 | 1.75 | 2.36 | 10.77 | 10.44 | 4 | 6.50 | 5.94 | AWF 24# | |
| Nominal Size | TPI | Max. | Min. | Max. | Min. | H | Max. | Min. | Max. | Min. | T | R | Max. | Min. | # | Max. | Min. | Depth | 打字 |

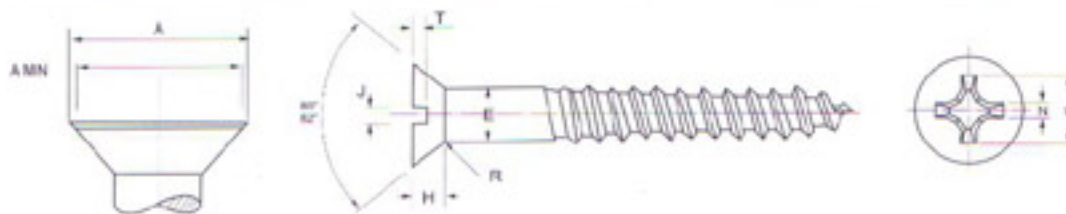
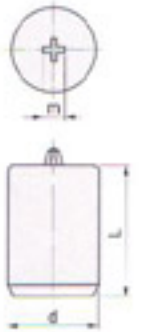

AUF (ANSI UNDERCUT HEAD MACHINE & TAPPING SCREW)

| 規格 | 頭部外徑 | | 頭深 | | 溝寬 | | 溝深 | | 沖模間隙 | | 十字寬 | | # | 十字深 | | 打字 | | | |
|--------------|-------|-------|-------|------|------|------|------|------|------|------|------|-------|-------|-------|----|------|-------|------------------|----|
| | 上限 | 下限 | 上限 | 下限 | 上限 | 下限 | 上限 | 下限 | 上限 | 下限 | 上限 | 下限 | | 上限 | 下限 | | | | |
| | A | | H | | J | | T | | F | | G | | | M | | | Depth | | |
| 0 | 1.52 | 3.02 | 2.51 | 0.64 | 0.46 | 0.58 | 0.41 | 0.28 | 0.18 | ** | ** | ** | 1.75 | 1.42 | 0 | 0.91 | 0.51 | AUF 2# AUF 3# | |
| 1 | 1.85 | 3.71 | 3.12 | 0.79 | 0.58 | 0.66 | 0.48 | 0.36 | 0.23 | ** | ** | ** | 1.96 | 1.63 | 0 | 1.12 | 0.71 | | |
| 2 | 2.18 | 4.37 | 3.73 | 0.91 | 0.71 | 0.79 | 0.58 | 0.41 | 0.28 | 0.74 | 0.43 | 3.15 | 2.41 | 2.08 | 1 | 1.24 | 0.84 | | |
| 3 | 2.51 | 5.05 | 4.34 | 1.07 | 0.84 | 0.89 | 0.69 | 0.48 | 0.30 | 0.79 | 0.46 | 3.76 | 2.59 | 2.25 | 1 | 1.42 | 1.02 | | |
| 4 | 2.84 | 5.72 | 4.95 | 1.19 | 0.97 | 0.99 | 0.79 | 0.56 | 0.36 | 0.81 | 0.48 | 4.37 | 2.97 | 2.64 | 1 | 1.80 | 1.40 | AUF 4# | |
| 5 | 3.18 | 6.40 | 5.59 | 1.35 | 1.09 | 1.09 | 0.89 | 0.61 | 0.41 | 0.80 | 0.51 | 4.98 | 3.25 | 2.92 | 1 | 2.08 | 1.60 | AUF 5# | |
| 6 | 3.51 | 7.09 | 6.20 | 1.50 | 1.22 | 1.22 | 0.99 | 0.69 | 0.43 | 0.91 | 0.53 | 5.59 | 3.71 | 3.35 | 2 | 1.70 | 1.12 | AUF 6# | |
| 7 | 3.84 | 7.75 | 6.81 | 1.63 | 1.35 | 1.22 | 0.99 | 0.76 | 0.46 | 0.94 | 0.56 | 6.17 | 3.91 | 3.58 | 2 | 1.90 | 1.32 | AUF 7# | |
| 8 | 4.17 | 8.43 | 7.42 | 1.78 | 1.47 | 1.37 | 1.14 | 0.81 | 0.53 | 0.99 | 0.58 | 6.78 | 4.42 | 4.09 | 2 | 2.41 | 1.83 | AUF 8# | |
| 10 | 4.83 | 9.78 | 8.64 | 2.06 | 1.73 | 1.52 | 1.27 | 0.94 | 0.61 | 1.07 | 0.64 | 7.95 | 4.90 | 4.47 | 2 | 2.79 | 2.21 | AUF 10# | |
| 12 | 5.49 | 11.13 | 9.88 | 2.34 | 1.98 | 1.70 | 1.42 | 1.09 | 0.71 | 1.14 | 0.69 | 9.19 | 5.32 | 5.59 | 3 | 2.64 | 2.06 | AUF 12# | |
| 14 | 6.35 | 12.88 | 11.48 | 2.72 | 2.34 | 1.90 | 1.63 | 1.27 | 0.81 | 1.27 | 0.74 | 10.77 | 6.35 | 6.02 | 3 | 3.02 | 2.44 | AUF 14# | |
| 5/16 | 7.04 | 16.13 | 14.43 | 3.40 | 2.95 | 2.13 | 1.83 | 1.57 | 1.04 | 1.45 | 0.86 | 13.69 | 8.05 | 7.72 | 4 | 3.76 | 3.20 | AUF 5/16 | |
| 3/8 | 8.53 | 19.35 | 17.40 | 4.09 | 3.56 | 2.39 | 2.06 | 1.90 | 1.24 | 1.65 | 0.99 | 16.59 | 9.27 | 8.94 | 4 | 4.98 | 4.42 | AUF 3/8 | |
| 7/16 | 11.11 | 20.62 | 18.30 | 3.96 | 3.36 | 2.39 | 2.06 | 1.83 | 1.14 | 1.86 | 1.12 | 17.53 | 9.98 | 9.65 | 4 | 5.72 | 5.16 | AUF 7/16 | |
| 1/2 | 12.70 | 22.23 | 19.68 | 3.96 | 3.30 | 2.69 | 2.31 | 1.83 | 1.17 | 2.06 | 1.24 | 18.77 | 10.39 | 10.05 | 4 | 6.12 | 5.56 | AUF 1/2 | |
| Nominal Size | Max. | Min. | Max. | Min. | Max. | Min. | Max. | Min. | Max. | Min. | F | G | Max. | Min. | # | Max. | Min. | Depth | 打字 |

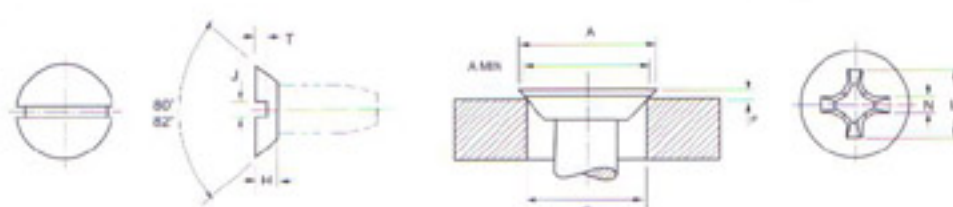
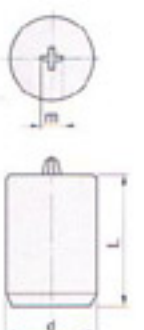

螺絲檢測規

P - 插規
 PHILLIPS PLUG GAUGE
 (#0. #1. #2. #3. #4.)



P - 插規
 POZIDRIV PLUG GAUGE
 (#0. #1. #2. #3. #4.)



P - 插規
 SQUARE PLUG GAUGE
 (#0. #1. #2. #3. #4.)



Q - 深度規
 PHILLIPS
 PENETRATION GAUGE
 (#0. #1. #2. #3. #4.)

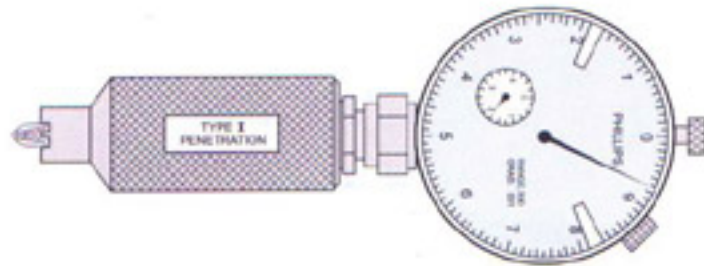

Q - 深度規
 POZIDRIV
 PENETRATION GAUGE
 (#0. #1. #2. #3. #4.)

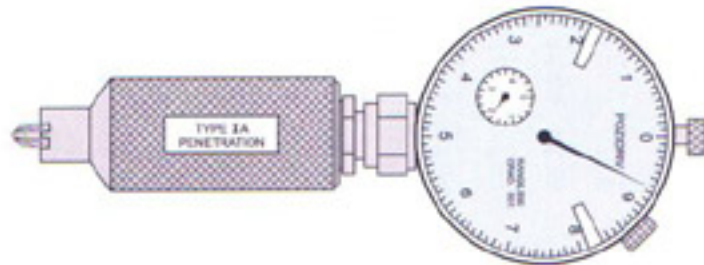

Q - 深度規
 SQUARE
 PENETRATION GAUGE
 (#0. #1. #2. #3. #4.)



梅花規格對照表

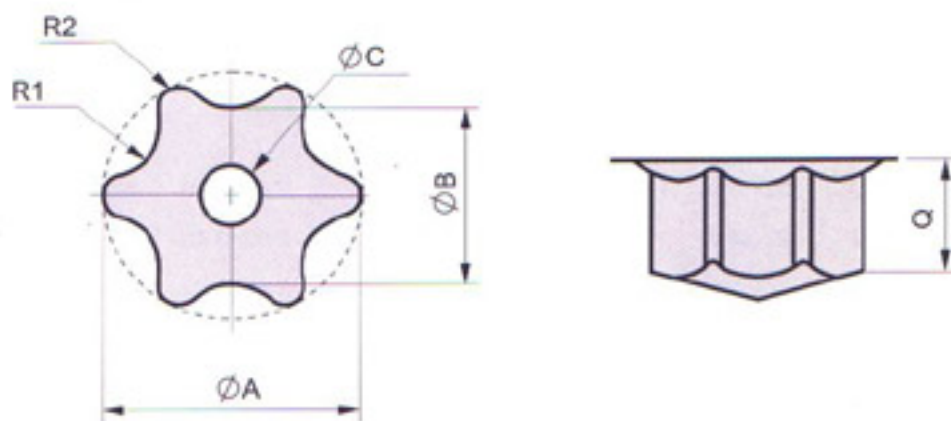

| SIX-LOBE 梅花規格 | ϕA (外切圓) | ϕB (內切圓) | R1 (大R) | R2 (小R) | ϕC (鑽孔) | 備 注 |
|------------------|-------------------|-------------------|------------|------------|------------------|-----|
| T5 | 1.48 | 1.07 | 0.30 | 0.13 | | |
| T6 | 1.75 | 1.27 | 0.36 | 0.16 | | |
| T7 | 2.06 | 1.49 | 0.42 | 0.19 | | |
| T8 | 2.39 | 1.73 | 0.49 | 0.22 | 0.60 | |
| T9 | 2.57 | 1.86 | 0.53 | 0.23 | | |
| T10 | 2.82 | 2.03 | 0.57 | 0.25 | 0.80 | |
| T15 | 3.35 | 2.41 | 0.69 | 0.29 | 1.00 | |
| T20 | 3.94 | 2.83 | 0.83 | 0.33 | 1.40 | |
| T25 | 4.52 | 3.24 | 0.89 | 0.41 | 1.80 | |
| T27 | 5.08 | 3.64 | 1.05 | 0.43 | 2.00 | |
| T30 | 5.63 | 4.05 | 1.16 | 0.48 | 2.30 | |
| T40 | 6.76 | 4.84 | 1.40 | 0.58 | 2.60 | |
| T45 | 7.92 | 5.65 | 1.72 | 0.64 | 3.20 | |
| T50 | 8.94 | 6.45 | 1.78 | 0.81 | 3.60 | |
| T55 | 11.33 | 8.10 | 2.46 | 0.92 | 4.60 | |



POZI 米字規格對照表

FLAT HEAD

| 規格 | Q | M | 規格 | Q | M | 規格 | Q | M |
|---------|-----------|------|-------|-----------|------|--------|-----------|------|
| EZ-2 | 0.92~1.17 | 2.20 | 2Z-10 | 1.34~1.80 | 3.70 | 2Z-40 | 2.64~3.10 | 5.00 |
| 1Z-10 | 1.10~1.35 | 2.40 | 2Z-48 | 1.60~2.06 | 4.00 | 2Z-75 | 2.99~3.45 | 5.30 |
| 1Z-20 | 1.22~1.47 | 2.50 | 2Z-11 | 1.85~2.31 | 4.20 | 3Z-850 | 2.46~2.92 | 6.10 |
| 1Z-540 | 1.48~1.73 | 2.80 | 2Z-60 | 2.05~2.51 | 4.40 | 3Z-11 | 2.72~3.18 | 6.30 |
| 1Z-30 | 1.76~2.01 | 3.10 | 2Z-30 | 2.26~2.72 | 4.70 | 3Z-20 | 2.99~3.45 | 6.60 |
| 2Z-2850 | 1.14~1.60 | 3.65 | 2Z-76 | 2.46~2.92 | 4.80 | 3Z-30 | 3.38~3.84 | 7.00 |

PAN HEAD

| 規格 | Q | M | 規格 | Q | M | 規格 | Q | M |
|--------|-----------|------|--------|-----------|------|---------|-----------|------|
| 1Z-130 | 1.10~1.35 | 2.40 | 2Z-200 | | | 3Z-210 | 2.51~2.97 | 6.20 |
| 1Z-140 | 1.18~1.59 | 2.70 | 2Z-210 | 1.47~1.93 | 3.90 | 3Z-220 | 3.02~3.48 | 6.70 |
| 1Z-150 | 1.58~1.83 | 2.90 | 2Z-220 | 1.70~2.16 | 4.10 | 3Z-1850 | 3.32~3.78 | 7.00 |
| | | | 2Z-230 | 1.88~2.34 | 4.30 | 4Z-90 | 3.71~4.17 | 8.50 |
| | | | 2Z-43 | 2.07~2.53 | 4.50 | | | |
| | | | 2Z-250 | 2.28~2.74 | 4.70 | | | |

OVAL HEAD

| 規格 | D | Q | M | 規格 | D | Q | M | 規格 | D | Q | M |
|-------|-----|-----------|------|------------|-----|-----------|------|------------|------|-----------|------|
| 1Z-40 | 4.1 | 1.50~1.57 | 2.78 | 2Z-80 | 6.8 | 2.21~2.36 | 4.42 | 2Z-22 | 9.7 | 2.89~3.35 | 5.30 |
| 1Z-11 | 4.4 | 1.10~1.35 | 2.40 | 2Z-15 | 6.9 | 1.88~2.34 | 4.30 | PZ7995 5.0 | 9.7 | 3.19~3.30 | 5.30 |
| 1Z-22 | 4.7 | 1.50~1.75 | 2.80 | 2Z-140 | 7.4 | 2.36~2.51 | 4.57 | 3Z-110 | 10.7 | 3.27~3.42 | 6.76 |
| 1Z-50 | 4.8 | 1.80~1.87 | 3.08 | 2Z-18 | 7.5 | 2.26~2.72 | 4.70 | 3Z-12 | 10.7 | 2.92~3.38 | 6.60 |
| 1Z-60 | 5.5 | 2.11~2.18 | 3.39 | 2Z-120 | 8.1 | 2.59~2.74 | 4.80 | PZ7995 5.5 | 10.7 | 3.22~3.38 | 6.72 |
| 1Z-14 | 5.6 | 1.83~2.08 | 3.10 | PZ7983 4.2 | 8.2 | 2.56~2.72 | 4.78 | 3Z-14 | 11.0 | 3.30~3.76 | 7.00 |
| 1Z-13 | 5.6 | 1.83~2.08 | 3.10 | PZ7995 4.5 | 8.6 | 3.00~3.15 | 5.21 | 3Z-120 | 12.4 | 3.78~3.93 | 7.27 |
| 2Z-70 | 6.1 | 1.72~1.87 | 3.93 | 2Z-21 | 9.2 | 2.69~3.15 | 5.10 | 3Z-15 | 12.6 | 3.40~3.86 | 7.10 |
| 2Z-16 | 6.5 | 1.83~2.39 | 4.30 | 2Z-130 | 9.4 | 3.02~3.17 | 5.23 | 3Z-17 | 13.0 | 4.34~4.80 | 8.00 |



POZI 米字規格對照表

ANSI MACHINE & TAPPING

| 規格 | #2 | #3 | #4 | #5 | #6 | #7 | #8 | #10 | #12 | 1/4 |
|-----------|---------|--------|---------|---------|---------|---------|---------|---------|---------|---------|
| FLAT | 1Z-10 | 1Z-20 | 1Z-30 | 2Z-10 | 2Z-11 | 2Z-60 | 2Z-30 | 2Z-40 | 3Z-20 | 3Z-30 |
| OVAL | 1Z-40 | 1Z-50 | 1Z-60 | 2Z-70 | 2Z-80 | 2Z-140 | 2Z-120 | 2Z-130 | 3Z-110 | 3Z-120 |
| ROUND | | | 1Z-440 | 2Z-300 | 2Z-150 | 2Z-160 | 2Z-170 | 2Z-190 | 3Z-160 | 3Z-190 |
| PAN | 1Z-130 | 1Z-140 | 1Z-150 | 2Z-200 | 2Z-210 | 2Z-220 | 2Z-230 | 2Z-250 | 3Z-210 | 3Z-220 |
| TRUSS | 1Z-1000 | 1Z-190 | 1Z-1020 | 2Z-1030 | 2Z-3210 | 2Z-3220 | 2Z-3230 | 2Z-3240 | 3Z-1670 | 3Z-1680 |
| BINDING | 1Z-630 | 1Z-640 | 1Z-620 | 2Z-1440 | 2Z-1330 | | 2Z-1450 | 2Z-1430 | 3Z-960 | 3Z-970 |
| FILLISTER | 1Z-130 | 1Z-140 | 1Z-150 | 2Z-3460 | 2Z-210 | 2Z-220 | 2Z-230 | 2Z-250 | 3Z-210 | 3Z-220 |

ANSI WOOD

| 規格 | #2 | #3 | #4 | #5 | #6 | #7 | #8 | #9 | #10 | #12 | 1/4 |
|-------|-------|-------|-------|--------|--------|--------|--------|--------|--------|--------|--------|
| FLAT | 1Z-10 | 1Z-20 | 1Z-30 | 2Z-10 | 2Z-11 | 2Z-30 | 2Z-40 | 2Z-50 | 3Z-10 | 3Z-30 | 3Z-40 |
| OVAL | 1Z-40 | 1Z-50 | 1Z-60 | 2Z-70 | 2Z-80 | 2Z-90 | 2Z-100 | 2Z-110 | 3Z-60 | 3Z-80 | 3Z-90 |
| ROUND | | | | 2Z-300 | 2Z-150 | 2Z-160 | 2Z-170 | | 2Z-190 | 3Z-160 | 3Z-170 |

DIN MACHINE

| 規格 | M2 | M2.5 | M3 | M3.5 | M4 | M5 | M6 | M8 | M10 |
|-----------|----|-------|--------|-------|-------|-------|--------|---------|-------|
| F DIN965 | | 1Z-20 | 1Z-540 | 2Z-10 | 2Z-48 | 2Z-60 | 3Z-850 | 4Z-1060 | 4Z-10 |
| O DIN966 | | 1Z-22 | 1Z-14 | 2Z-16 | 2Z-18 | 2Z-22 | 3Z-14 | 4Z-19 | 4Z-85 |
| L DIN7985 | | 1Z-21 | 1Z-23 | 2Z-47 | 2Z-35 | 2Z-37 | 3Z-220 | 4Z-19 | 4Z-86 |

DIN TAPPING

| 規格 | 2.2 | 2.9 | 3.5 | 3.9 | 4.2 | 4.8 | 5.5 | 6.3 |
|-----------|--------|--------|--------|--------|--------|--------|--------|--------|
| F DIN7982 | 1Z-10 | 1Z-540 | 2Z-48 | 2Z-11 | 2Z-60 | 2Z-40 | 3Z-11 | 3Z-30 |
| O DIN7983 | 1Z-11 | 1Z-13 | 2Z-15 | 2Z-17 | 2Z-18 | 2Z-21 | 3Z-12 | 3Z-15 |
| P DIN7981 | 1Z-130 | 1Z-150 | 2Z-210 | 2Z-220 | 2Z-230 | 2Z-250 | 3Z-210 | 3Z-220 |

DIN WOOD

| 規格 | 2.5 | 3 | 3.5 | 4 | 4.5 | 5 | 5.5 | 6 | 7 | 8 |
|-----------|--------|--------|--------|--------|--------|--------|--------|--------|---------|---------|
| F DIN7997 | 1Z-540 | 1Z-30 | 2Z-48 | 2Z-60 | 2Z-76 | 2Z-75 | 3Z-11 | 3Z-20 | 3Z-30 | 4Z-1060 |
| O DIN7995 | 1Z-22 | 1Z-14 | 2Z-16 | 2Z-18 | 2Z-21 | 2Z-22 | 3Z-12 | 3Z-14 | 3Z-17 | 4Z-19 |
| R DIN7996 | 1Z-130 | 1Z-150 | 2Z-210 | 2Z-220 | 2Z-230 | 2Z-250 | 3Z-210 | 3Z-220 | 3Z-1850 | |



POZI 米字 DIN 規格對照表

| DIN 965 (DIN FLAT HEAD MACHINE SCREW) | | | | DIN 966 (DIN OVAL HEAD MACHINE SCREW) | | | |
|--|-------|------|------|---|-------|------|------|
| POZI | 規格 | Q | | POZI | 規格 | Q | |
| 1Z-20 | M2.5 | 1.47 | 1.40 | 1Z-22 | M2.5 | 1.75 | 1.68 |
| 1Z-540 | M3.0 | 1.73 | 1.65 | 1Z-14 | M3.0 | 2.08 | 2.01 |
| 2Z-10 | M3.5 | 1.80 | 1.65 | 2Z-16 | M3.5 | 2.39 | 2.24 |
| 2Z-48 | M4.0 | 2.06 | 1.90 | 2Z-18 | M4.0 | 2.72 | 2.56 |
| 2Z-60 | M5.0 | 2.51 | 2.36 | 2Z-22 | M5.0 | 3.35 | 3.20 |
| 3Z-850 | M6.0 | 2.92 | 2.77 | 3Z-14 | M6.0 | 3.76 | 3.61 |
| 4Z-1060 | M8.0 | 4.32 | 4.17 | 4Z-19 | M8.0 | 4.52 | 4.37 |
| 4Z-10 | M10.0 | 5.23 | 5.08 | 4Z-85 | M10.0 | 5.74 | 5.59 |
| DIN 7981 (DIN PAN HEAD TAPPING SCREW) | | | | DIN 7982 (DIN FLAT HEAD TAPPING SCREW) | | | |
| POZI | 規格 | Q | | POZI | 規格 | Q | |
| 1Z-130 | M2.2 | 1.35 | 1.27 | 1Z-10 | M2.2 | 1.35 | 1.27 |
| 1Z-150 | M2.9 | 1.83 | 1.75 | 1Z-540 | M2.9 | 1.73 | 1.65 |
| 2Z-210 | M3.5 | 1.93 | 1.78 | 2Z-48 | M3.5 | 2.06 | 1.90 |
| 2Z-220 | M3.9 | 2.16 | 2.01 | 2Z-11 | M3.9 | 2.31 | 2.16 |
| 2Z-230 | M4.2 | 2.34 | 2.18 | 2Z-60 | M4.2 | 2.51 | 2.36 |
| 2Z-250 | M4.8 | 2.74 | 2.59 | 2Z-40 | M4.8 | 3.10 | 2.95 |
| 3Z-210 | M5.5 | 2.97 | 2.82 | 3Z-11 | M5.5 | 3.18 | 3.02 |
| 3Z-220 | M6.3 | 3.48 | 3.33 | 3Z-30 | M6.3 | 3.84 | 3.68 |
| DIN 7983 (DIN OVAL HEAD TAPPING SCREW) | | | | DIN 7985 (DIN FILLISTER HEAD MACHINE SCREW) | | | |
| POZI | 規格 | Q | | POZI | 規格 | Q | |
| 1Z-11 | M2.2 | 1.35 | 1.27 | 0Z-3 | M2.0 | 1.42 | 1.35 |
| 1Z-13 | M2.9 | 2.08 | 2.01 | 1Z-21 | M2.5 | 1.62 | 1.45 |
| 2Z-15 | M3.5 | 2.34 | 2.18 | 1Z-23 | M3.0 | 1.93 | 1.85 |
| 2Z-17 | M3.9 | 2.46 | 2.31 | 2Z-47 | M3.5 | 2.11 | 1.96 |
| 2Z-18 | M4.2 | 2.72 | 2.56 | 2Z-35 | M4.0 | 2.36 | 2.21 |
| 2Z-21 | M4.8 | 3.15 | 3.00 | 2Z-37 | M5.0 | 3.10 | 2.95 |
| 3Z-12 | M5.5 | 3.38 | 3.22 | 3Z-220 | M6.0 | 3.48 | 3.33 |
| 3Z-15 | M6.3 | 3.86 | 3.71 | 4Z-19 | M8.0 | 4.52 | 4.37 |
| | | | | 4Z-86 | M10.0 | 5.69 | 5.54 |
| DIN 7995 (DIN OVAL WOOD SCREW) | | | | DIN 7997 (DIN FLAT WOOD SCREW) | | | |
| POZI | 規格 | Q | | POZI | 規格 | Q | |
| 1Z-22 | M2.5 | 1.75 | 1.68 | 1Z-540 | M2.5 | 1.73 | 1.65 |
| 1Z-14 | M3.0 | 2.08 | 2.01 | 1Z-30 | M3.0 | 2.01 | 1.93 |
| 2Z-16 | M3.5 | 2.39 | 2.24 | 2Z-48 | M3.5 | 2.06 | 1.90 |
| 2Z-18 | M4.0 | 2.72 | 2.56 | 2Z-60 | M4.0 | 2.51 | 2.36 |
| 2Z-21 | M4.5 | 3.15 | 3.00 | 2Z-76 | M4.5 | 2.92 | 2.77 |
| 2Z-22 | M5.0 | 3.35 | 3.20 | 2Z-75 | M5.0 | 3.45 | 3.30 |
| 3Z-12 | M5.5 | 3.38 | 3.22 | 3Z-11 | M5.5 | 3.18 | 3.02 |
| 3Z-14 | M6.0 | 3.76 | 3.61 | 3Z-20 | M6.0 | 3.45 | 3.30 |
| 3Z-17 | M7.0 | 4.80 | 4.65 | 3Z-30 | M7.0 | 3.84 | 3.68 |
| 4Z-19 | M8.0 | 4.52 | 4.37 | 4Z-1060 | M8.0 | 4.32 | 4.17 |



JPHT

H-TYPE LCM. JIS PAN HEAD

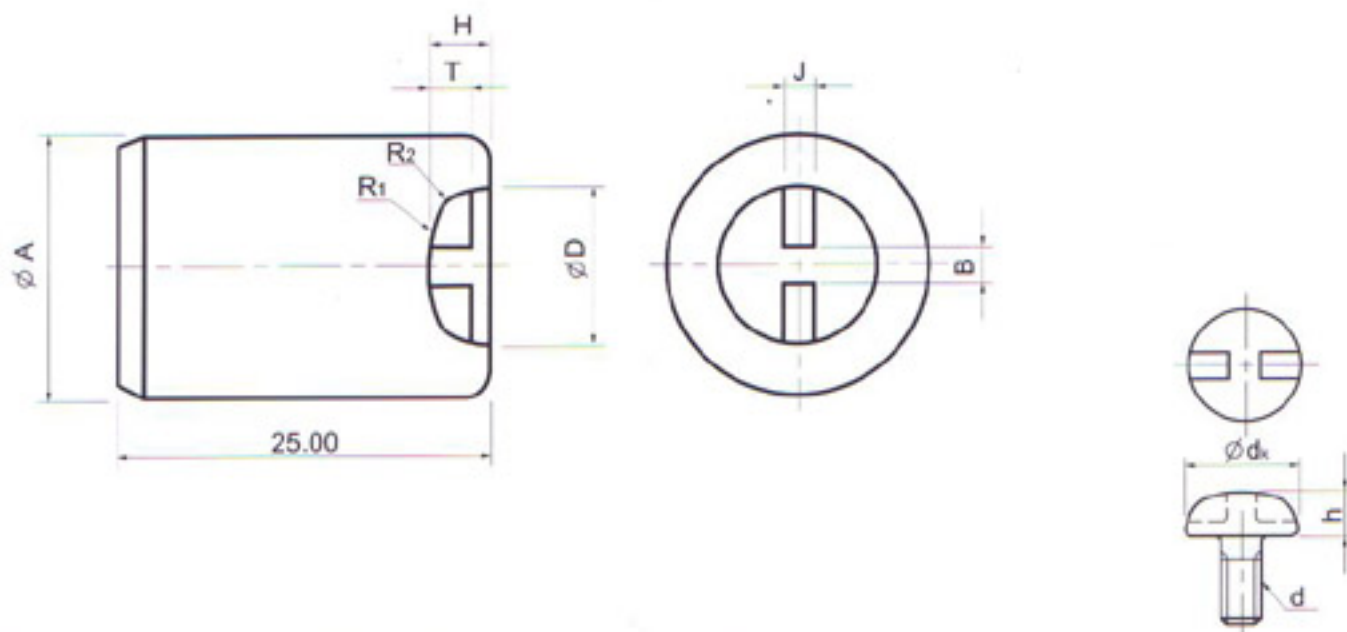

| d (公稱規格) | 沖頭尺寸 | | | | | | 螺絲尺寸 | | | |
|-------------|---|--------------|--------------|--------------|--------|----|---------|---------|-------|-------|
| | D $\begin{smallmatrix} +0.10 \\ -0 \end{smallmatrix}$ | H ± 0.05 | J ± 0.05 | T ± 0.05 | B (間距) | A | dk MAX. | dk MIN. | hMAX. | hMIN. |
| M20 | 3.50 | 1.20 | 0.75 | 0.75 | 0.70 | 12 | 3.50 | 3.10 | 1.40 | 1.20 |
| M23 | 4.00 | 1.40 | 0.80 | 0.85 | 0.80 | 12 | 4.00 | 3.60 | 1.60 | 1.40 |
| M26 | 4.50 | 1.40 | 1.00 | 1.00 | 0.90 | 12 | 4.50 | 4.10 | 1.80 | 1.60 |
| M30 | 5.50 | 1.70 | 1.20 | 1.25 | 1.00 | 12 | 5.50 | 5.00 | 2.15 | 1.85 |
| M35 | 6.00 | 1.90 | 1.25 | 1.35 | 1.50 | 12 | 6.00 | 5.50 | 2.45 | 2.15 |
| M40 | 7.00 | 2.20 | 1.40 | 1.50 | 1.70 | 14 | 7.00 | 6.50 | 2.75 | 2.45 |
| M45 | 8.00 | 2.50 | 1.50 | 1.75 | 1.80 | 14 | 8.00 | 7.40 | 3.05 | 2.75 |
| M50 | 9.00 | 2.80 | 1.70 | 2.00 | 1.90 | 14 | 9.00 | 8.40 | 3.45 | 3.15 |



AFSQ (英制)

SQUARE ANSI FLAT HEAD

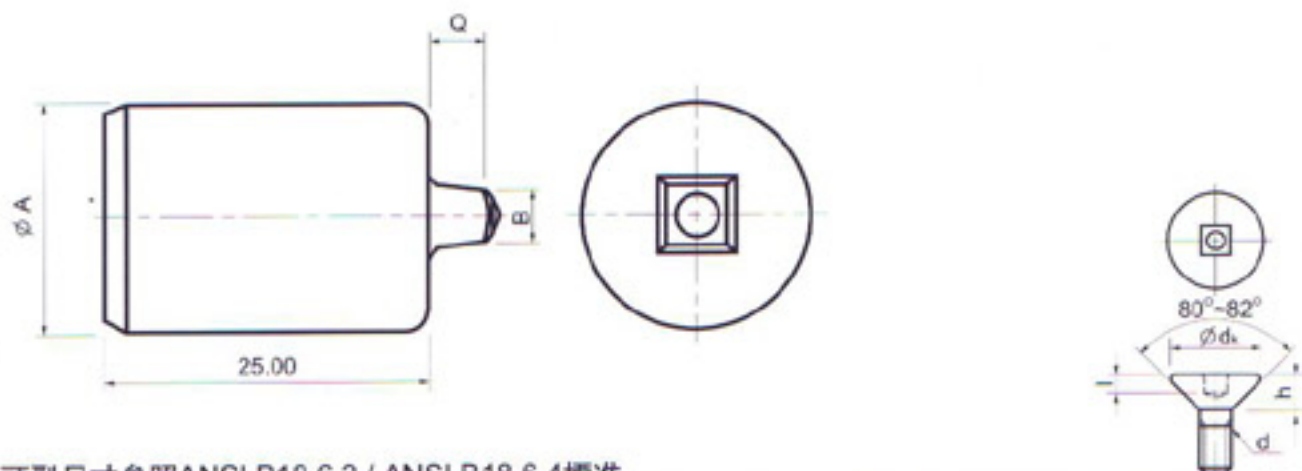

螺絲頭型尺寸參照ANSI B18.6.3 / ANSI B18.6.4標準。

| d (公稱規格) | 槽深等級 | 沖頭尺寸 | | | | 螺絲尺寸 | | | | |
|-------------|------|-----------------------------|---------------------------------|----|-------|---------------------|---------------------|-------------------|--------|--------|
| | | B _{REF.} (方孔對邊) | Q ^{+0.05} ₀ | A | PUNCH | d _K MAX. | d _K MIN. | h _{REF.} | l MAX. | l MIN. |
| #3 | -01 | 1.78 | 0.95 | 12 | 0 | 5.05 | 4.34 | 1.50 | 1.10 | 0.75 |
| #4 | -01 | 1.78 | 1.00 | 12 | | 5.72 | 4.95 | 1.70 | 1.10 | 0.75 |
| #5 | -13 | 2.30 | 1.50 | 12 | 1 | 6.40 | 5.59 | 1.90 | 1.60 | 1.15 |
| #6 | -14 | 2.30 | 1.80 | 12 | | 7.09 | 6.20 | 2.11 | 1.90 | 1.55 |
| #7 | -15 | 2.30 | 2.10 | 12 | | 7.75 | 6.81 | 2.31 | 2.20 | 1.55 |
| #6 | -24 | 2.85 | 1.60 | 12 | 2 | 7.09 | 6.20 | 2.11 | 1.70 | 1.40 |
| #7 | -25 | 2.85 | 1.80 | 12 | | 7.75 | 6.81 | 2.31 | 1.90 | 1.40 |
| #8 | -26 | 2.85 | 2.00 | 12 | | 8.43 | 7.42 | 2.54 | 2.10 | 1.80 |
| #10 | -27 | 2.85 | 2.25 | 14 | | 9.78 | 8.64 | 2.95 | 2.40 | 1.80 |
| #12 | -32 | 3.36 | 1.95 | 18 | 3 | 11.13 | 9.88 | 3.35 | 2.10 | 1.30 |
| #12 | -33 | 3.36 | 2.25 | 18 | | 11.13 | 9.88 | 3.35 | 2.40 | 1.50 |
| 1/4 | -34 | 3.36 | 2.60 | 18 | | 12.88 | 11.48 | 3.89 | 2.70 | 1.90 |
| 5/16 | -41 | 4.84 | 3.30 | 23 | 4 | 16.13 | 14.43 | 4.85 | 3.40 | 2.40 |
| 3/8 | -42 | 4.84 | 3.50 | 23 | | 19.35 | 17.40 | 5.84 | 3.60 | 2.40 |



DF6H (公制)

HEX. DIN 7991 FLAT HEAD

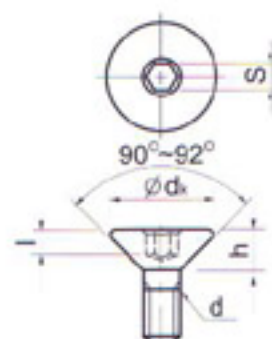
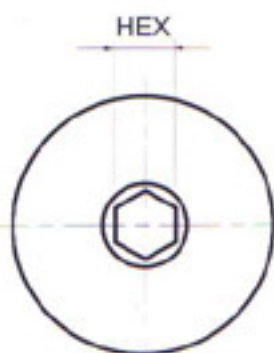
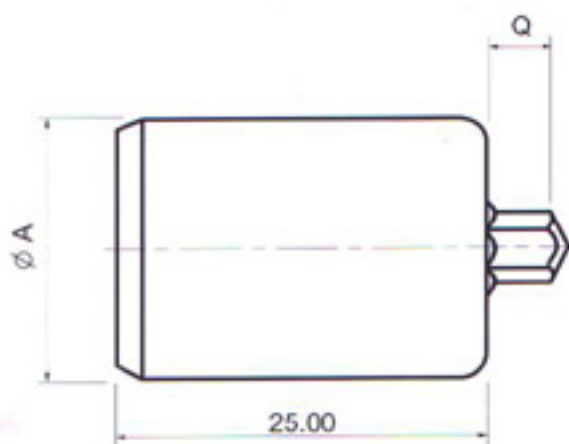

螺絲頭型尺寸參照DIN 7991標準.

| d (公稱規格) | 沖頭尺寸 | | | 螺絲尺寸 | | | | | |
|-------------|---------------|------------------|----|------------|------------|----------|--------|--------|--------|
| | HEX (公稱對邊) | $Q_{-0}^{+0.05}$ | A | d_k MAX. | d_k MIN. | h MAX. | S MAX. | S MIN. | l MAX. |
| M2.0 | 1.30 | 0.70 | 12 | 4.00 | 3.70 | 1.20 | 1.38 | 1.32 | 0.75 |
| M2.5 | 1.50 | 0.75 | 12 | 5.00 | 4.70 | 1.50 | 1.58 | 1.52 | 0.80 |
| M3.0 | 2.00 | 1.15 | 12 | 6.00 | 5.70 | 1.70 | 2.10 | 2.02 | 1.20 |
| M4.0 | 2.50 | 1.75 | 12 | 8.00 | 7.64 | 2.30 | 2.60 | 2.52 | 1.80 |
| M5.0 | 3.00 | 2.25 | 14 | 10.00 | 9.64 | 2.80 | 3.10 | 3.02 | 2.30 |
| M6.0 | 4.00 | 2.45 | 14 | 12.00 | 11.57 | 3.30 | 4.12 | 4.02 | 2.50 |
| M8.0 | 5.00 | 3.40 | 18 | 16.00 | 15.57 | 4.40 | 5.14 | 5.02 | 3.50 |
| M10.0 | 6.00 | 4.30 | 23 | 20.00 | 19.48 | 5.50 | 6.14 | 6.02 | 4.40 |
| M12.0 | 8.00 | 4.50 | 30 | 24.00 | 23.48 | 6.50 | 8.175 | 8.025 | 4.60 |



JF6L (公制)

SIX-LOBE JIS FLAT HEAD

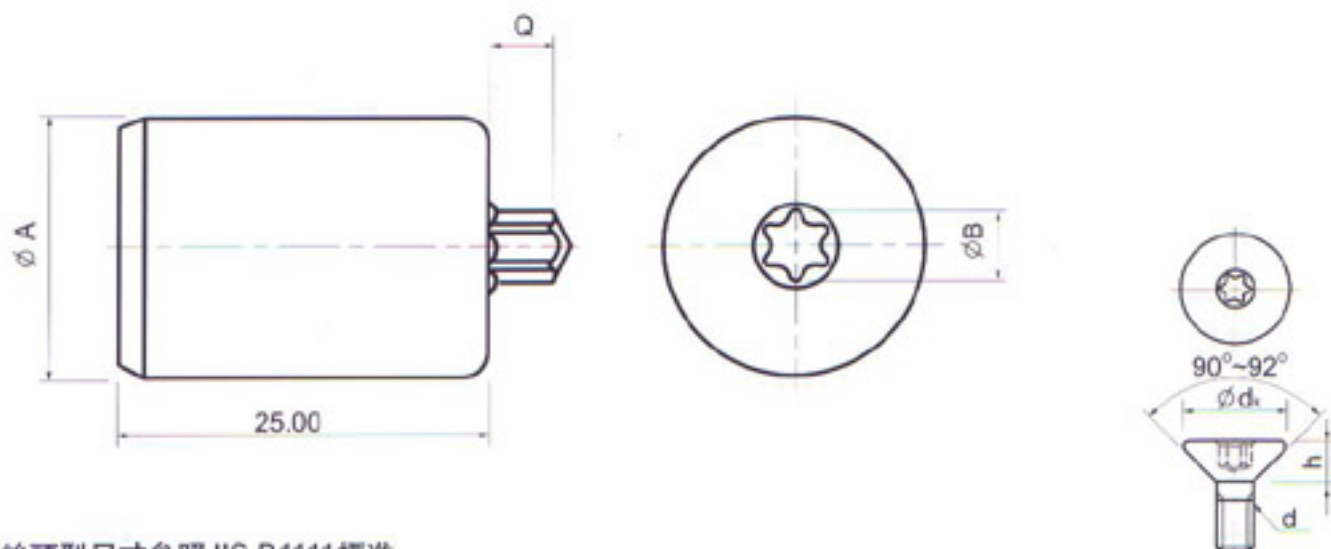

螺絲頭型尺寸參照JIS B1111標準.

| d (公稱規格) | SLX -LOBE (梅花槽型) | 沖頭尺寸 | | | 螺絲尺寸 | | | |
|-------------|------------------------|------|---------------------|----|---------------------|---------------------|--------|--------|
| | | B | $Q_{-0.05}^{+0.05}$ | A | d _K MAX. | d _K MIN. | h MAX. | h MIN. |
| | T5 | 1.48 | 0.60 | 12 | | | | |
| M20 | T6 | 1.75 | 0.80 | 12 | 4.00 | 3.60 | 1.20 | 1.00 |
| | T7 | 2.06 | 0.80 | 12 | | | | |
| M26 | T8 | 2.39 | 1.00 | 12 | 5.20 | 4.80 | 1.50 | 1.30 |
| | T9 | 2.57 | 1.10 | 12 | | | | |
| M30 | T10 | 2.82 | 1.20 | 12 | 6.00 | 5.50 | 1.75 | 1.45 |
| M35 | T15 | 3.35 | 1.40 | 12 | 7.00 | 6.50 | 2.00 | 1.70 |
| M40 | T20 | 3.94 | 1.60 | 14 | 8.00 | 7.50 | 2.30 | 2.00 |
| M50 | T25 | 4.52 | 1.80 | 14 | 10.00 | 9.40 | 2.80 | 2.50 |
| | T27 | 5.08 | 2.00 | 18 | | | | |
| M60 | T30 | 5.63 | 2.20 | 18 | 12.00 | 11.30 | 3.40 | 3.00 |
| M80 | T40 | 6.76 | 2.60 | 23 | 16.00 | 15.20 | 4.40 | 4.00 |



AF6L (英制)

SIX-LOBE ANSI FLAT HEAD

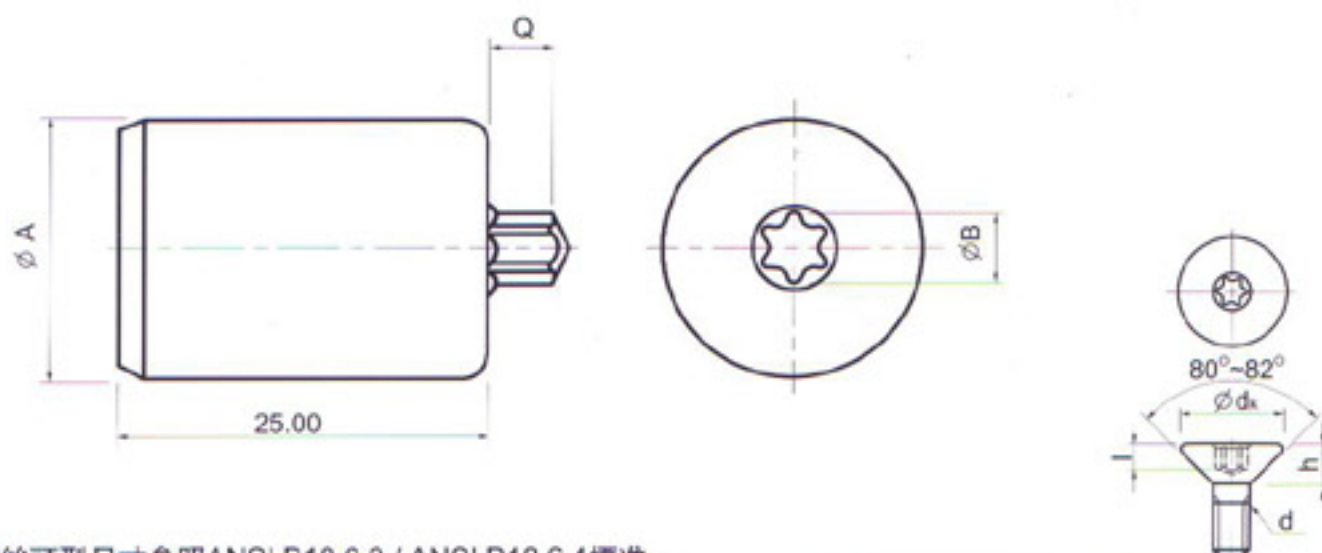

螺絲頭型尺寸參照ANSI B18.6.3 / ANSI B18.6.4標準.

| d (公稱規格) | SLX -LOBE (梅花槽型) | 沖頭尺寸 | | | 螺絲尺寸 | | | |
|-------------|------------------------|------|---------------|----|------------|------------|------------|------------|
| | | B | $Q_{+0.05}^0$ | A | d_k MAX. | d_k MIN. | $h_{REF.}$ | $l_{MIN.}$ |
| | T5 | 1.48 | 0.60 | 12 | | | | |
| #2 | T6 | 1.75 | 0.80 | 12 | 4.37 | 3.73 | 1.30 | 0.43 |
| | T7 | 2.06 | 0.80 | 12 | | | | |
| #4 | T8 | 2.39 | 1.00 | 12 | 5.72 | 4.95 | 1.70 | 0.71 |
| | T9 | 2.57 | 1.00 | 12 | | | | |
| #6 | T10 | 2.82 | 1.20 | 12 | 7.09 | 6.20 | 2.11 | 0.89 |
| #8 | T15 | 3.35 | 1.30 | 12 | 8.43 | 7.42 | 2.54 | 1.02 |
| #10 | T20 | 3.94 | 1.60 | 14 | 9.78 | 8.64 | 2.95 | 1.27 |
| #12 | T25 | 4.52 | 1.70 | 14 | 11.13 | 9.88 | 3.35 | 1.40 |
| 1/4 | T27 | 5.08 | 2.20 | 18 | 12.88 | 11.48 | 3.89 | 1.91 |
| | T30 | 5.63 | 2.50 | 18 | | | | |
| 5/16 | T40 | 6.78 | 2.70 | 23 | 16.13 | 14.43 | 4.85 | 2.21 |



AP6L (英制)

SIX-LOBE ANSI PAN HEAD

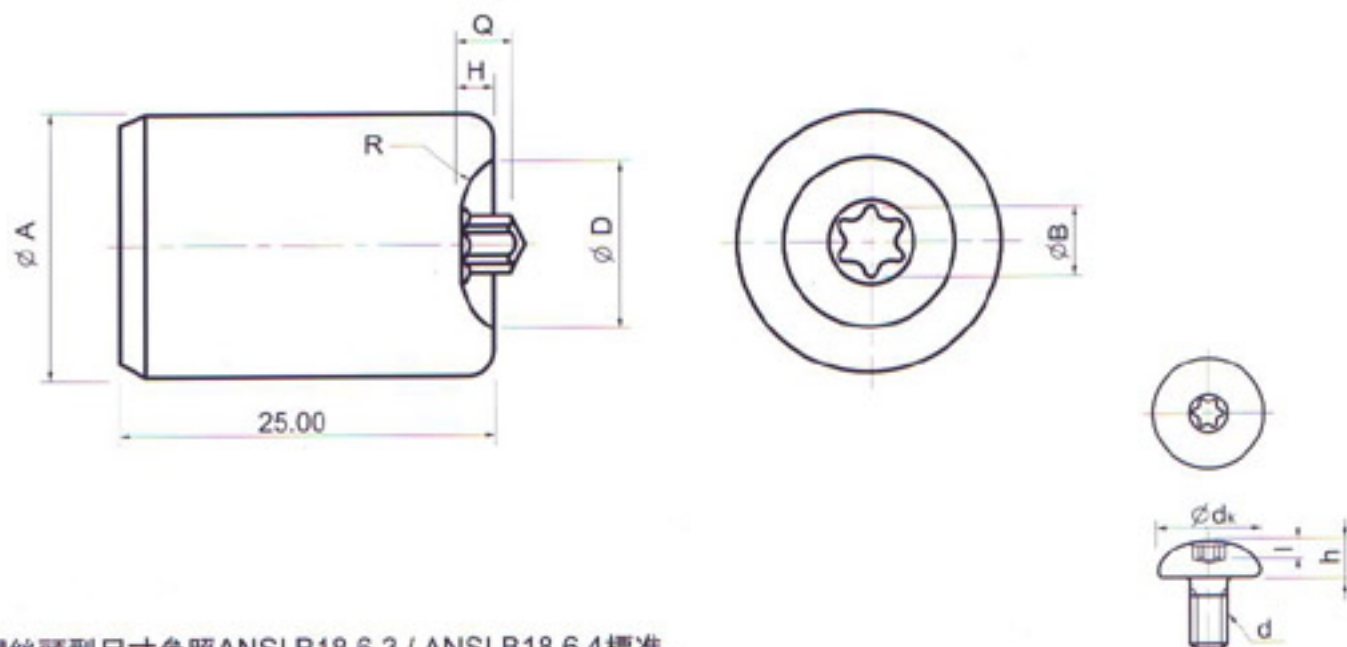

螺絲頭型尺寸參照ANSI B18.6.3 / ANSI B18.6.4標準.

| d (公稱規格) | SLX -LOBE (梅花槽型) | 沖頭尺寸 | | | | | | 螺絲尺寸 | | | | |
|-------------|------------------------|------|------------------|------------------|-------------------|-----------------|----|---------|---------|--------|--------|-------------------|
| | | B | $D_{-0}^{+0.10}$ | $H_{-0.10}^{+0}$ | R _{REF.} | $Q_{0}^{+0.05}$ | A | dk MAX. | dk MIN. | h MAX. | h MIN. | l _{MIN.} |
| #2 | T8 | 2.39 | 4.24 | 0.70 | 2.54 | 0.90 | 12 | 4.24 | 3.94 | 1.57 | 1.35 | 0.76 |
| #3 | T8 | 2.39 | 4.90 | 0.90 | 3.00 | 1.00 | 12 | 4.90 | 4.57 | 1.80 | 1.57 | 0.84 |
| #4 | T10 | 2.82 | 5.56 | 1.00 | 3.40 | 1.05 | 12 | 5.56 | 5.21 | 2.03 | 1.78 | 0.89 |
| #5 | T10 | 2.82 | 6.22 | 1.20 | 3.80 | 1.30 | 12 | 6.22 | 5.87 | 2.26 | 2.01 | 1.14 |
| #6 | T15 | 3.35 | 6.86 | 1.30 | 4.10 | 1.30 | 12 | 6.86 | 6.50 | 2.46 | 2.21 | 1.14 |
| #8 | T20 | 3.94 | 8.18 | 1.40 | 5.20 | 1.55 | 14 | 8.18 | 7.77 | 2.92 | 2.67 | 1.40 |
| #10 | T25 | 4.52 | 9.47 | 1.70 | 6.00 | 1.95 | 14 | 9.47 | 9.07 | 3.38 | 3.10 | 1.78 |
| #12 | T27 | 5.08 | 10.80 | 2.00 | 6.80 | 2.00 | 18 | 10.80 | 10.34 | 3.84 | 3.53 | 1.78 |
| 1/4 | T30 | 5.63 | 12.50 | 2.30 | 8.00 | 2.30 | 23 | 12.50 | 12.01 | 4.45 | 4.11 | 2.16 |



DL6L (公制)

SIX-LOBE DIN7985 FILLISTER HEAD

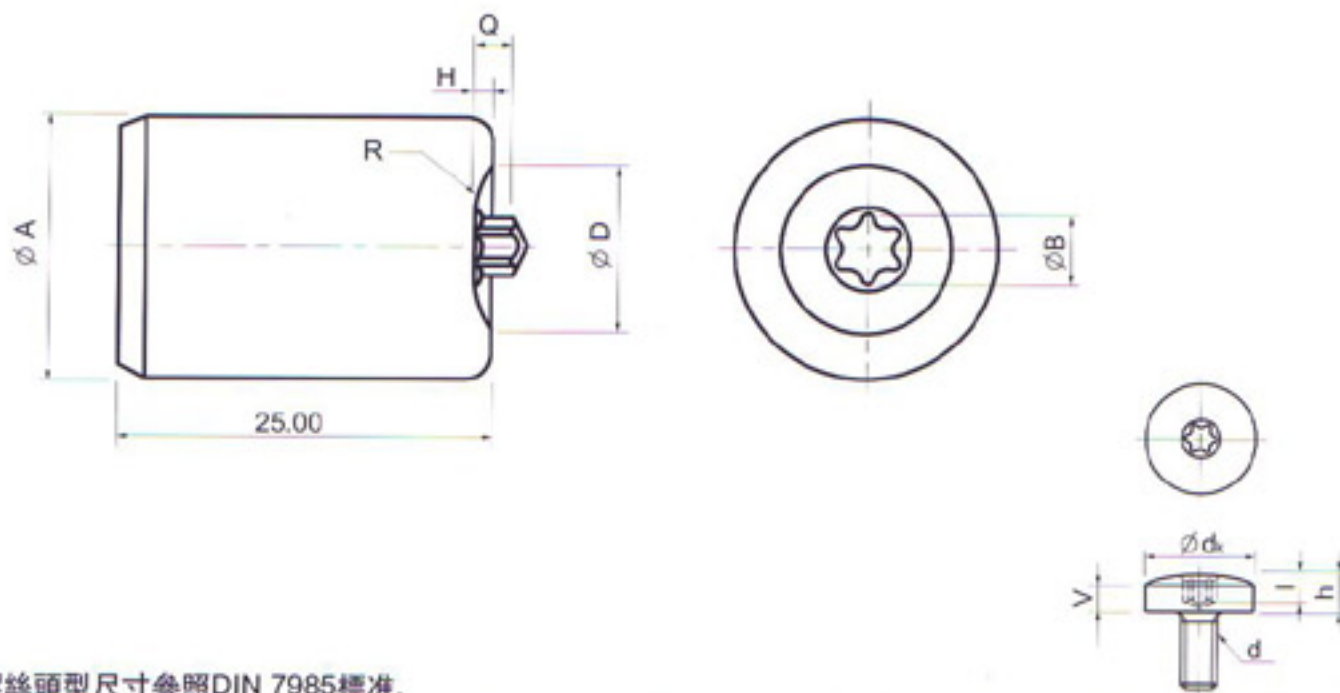

螺絲頭型尺寸參照DIN 7985標準.

| d (公稱規格) | SLX LOBE (梅花種類) | 沖頭尺寸 | | | | | | 螺絲尺寸 | | | | | |
|-------------|-----------------------|------|----------------------------------|----------------------------------|-------------------|----------------------------------|----|---------------------|---------------------|--------|--------|-------------------|-------------------|
| | | B | D ^{+0.10} ₋₀ | H ⁺⁰ _{-0.10} | R _{REF.} | Q ^{+0.05} ₋₀ | A | d _K MAX. | d _K MIN. | h MAX. | h MIN. | V _{REF.} | l _{MIN.} |
| M20 | T6 | 1.75 | 4.00 | 0.50 | 3.40 | 0.90 | 12 | 4.00 | 3.70 | 1.72 | 1.48 | 1.10 | 0.70 |
| M25 | T8 | 2.39 | 5.00 | 0.70 | 3.90 | 1.10 | 12 | 5.00 | 4.70 | 2.12 | 1.88 | 1.30 | 0.90 |
| M30 | T10 | 2.82 | 6.00 | 0.80 | 4.70 | 1.20 | 12 | 6.00 | 5.70 | 2.52 | 2.28 | 1.60 | 1.00 |
| M35 | T15 | 3.35 | 7.00 | 0.80 | 6.10 | 1.45 | 12 | 7.00 | 6.64 | 2.82 | 2.58 | 1.90 | 1.20 |
| M40 | T20 | 3.94 | 8.00 | 1.10 | 5.80 | 1.70 | 14 | 8.00 | 7.64 | 3.25 | 2.95 | 2.00 | 1.40 |
| M50 | T25 | 4.52 | 10.00 | 1.30 | 8.00 | 1.90 | 18 | 10.00 | 9.64 | 3.95 | 3.65 | 2.50 | 1.60 |
| M60 | T30 | 5.63 | 12.00 | 1.60 | 8.50 | 2.30 | 18 | 12.00 | 11.57 | 4.75 | 4.45 | 3.00 | 2.00 |
| M80 | T45 | 7.92 | 16.00 | 2.30 | 11.70 | 3.20 | 23 | 16.00 | 15.57 | 6.15 | 5.85 | 3.70 | 2.90 |



BT6L (公制)

SIX-LOBE ISO 7380 BUTTON HEAD

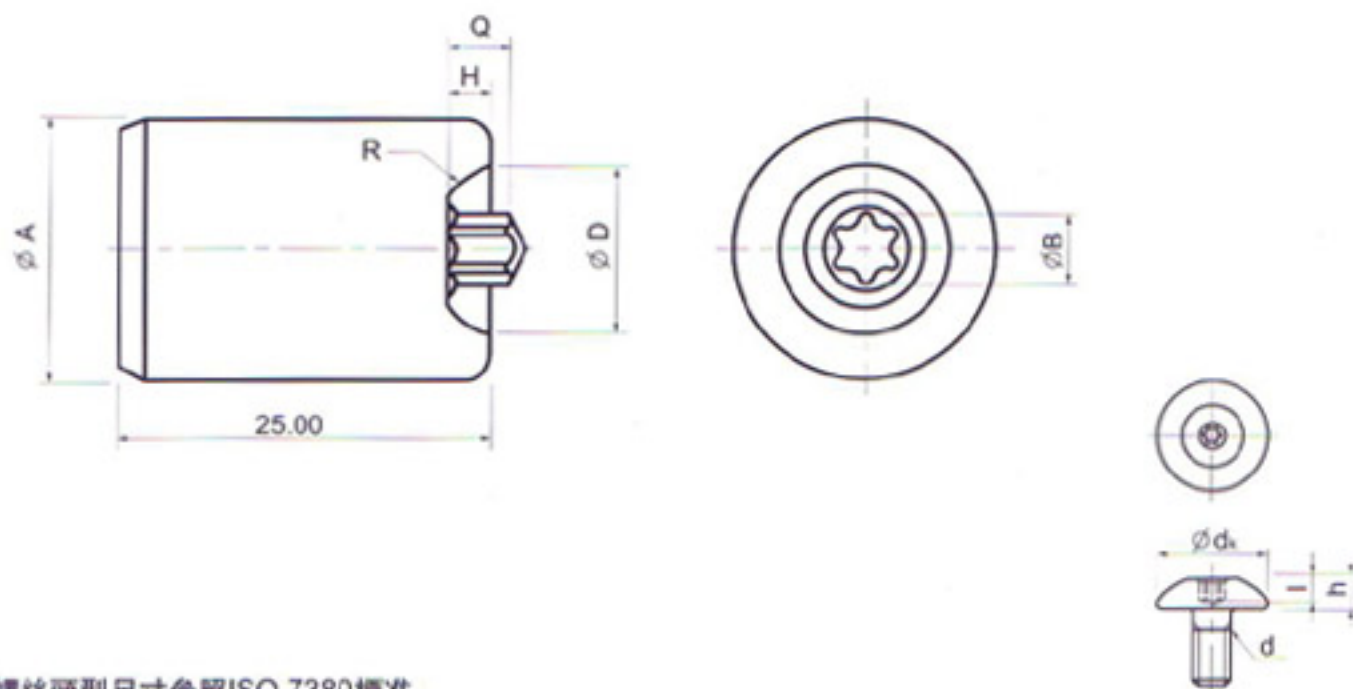

螺絲頭型尺寸參照ISO 7380標準。

| d (公制規格) | SLX -LOBE (梅花造型) | 沖頭尺寸 | | | | | | 螺絲尺寸 | | | | |
|-------------|------------------------|------|----------------------------------|----------------------------------|-------|----------------------------------|----|---------------------|---------------------|--------|--------|--------|
| | | B | D ^{+0.10} ₋₀ | H ⁺⁰ _{-0.10} | RREF. | Q ^{+0.05} ₋₀ | A | d _K MAX. | d _K MIN. | h MAX. | h MIN. | l MIN. |
| M2.0 | T6 | 1.75 | 3.60 | 0.96 | 1.80 | 0.75 | 12 | 3.50 | 3.30 | 1.30 | 1.16 | 0.85 |
| M2.5 | T8 | 2.39 | 4.80 | 1.16 | 2.50 | 0.90 | 12 | 4.70 | 4.50 | 1.50 | 1.36 | 0.75 |
| M3.0 | T10 | 2.82 | 5.80 | 1.20 | 3.20 | 0.95 | 12 | 5.70 | 5.40 | 1.65 | 1.40 | 0.80 |
| M4.0 | T20 | 3.94 | 7.80 | 1.75 | 4.20 | 1.30 | 14 | 7.60 | 7.24 | 2.20 | 1.95 | 1.15 |
| M5.0 | T25 | 4.52 | 9.70 | 2.20 | 5.30 | 1.55 | 18 | 9.50 | 9.14 | 2.75 | 2.50 | 1.41 |
| M6.0 | T30 | 5.63 | 10.70 | 2.60 | 5.60 | 1.85 | 18 | 10.50 | 10.07 | 3.30 | 3.00 | 1.65 |
| M8.0 | T40 | 6.76 | 14.20 | 3.70 | 7.50 | 2.55 | 23 | 14.00 | 13.57 | 4.40 | 4.10 | 2.35 |
| M10.0 | T50 | 8.94 | 17.70 | 4.70 | 9.30 | 2.75 | 30 | 17.50 | 17.07 | 5.50 | 5.20 | 2.55 |



BT6L (英制)

SIX-LOBE ANSI BUTTON HEAD

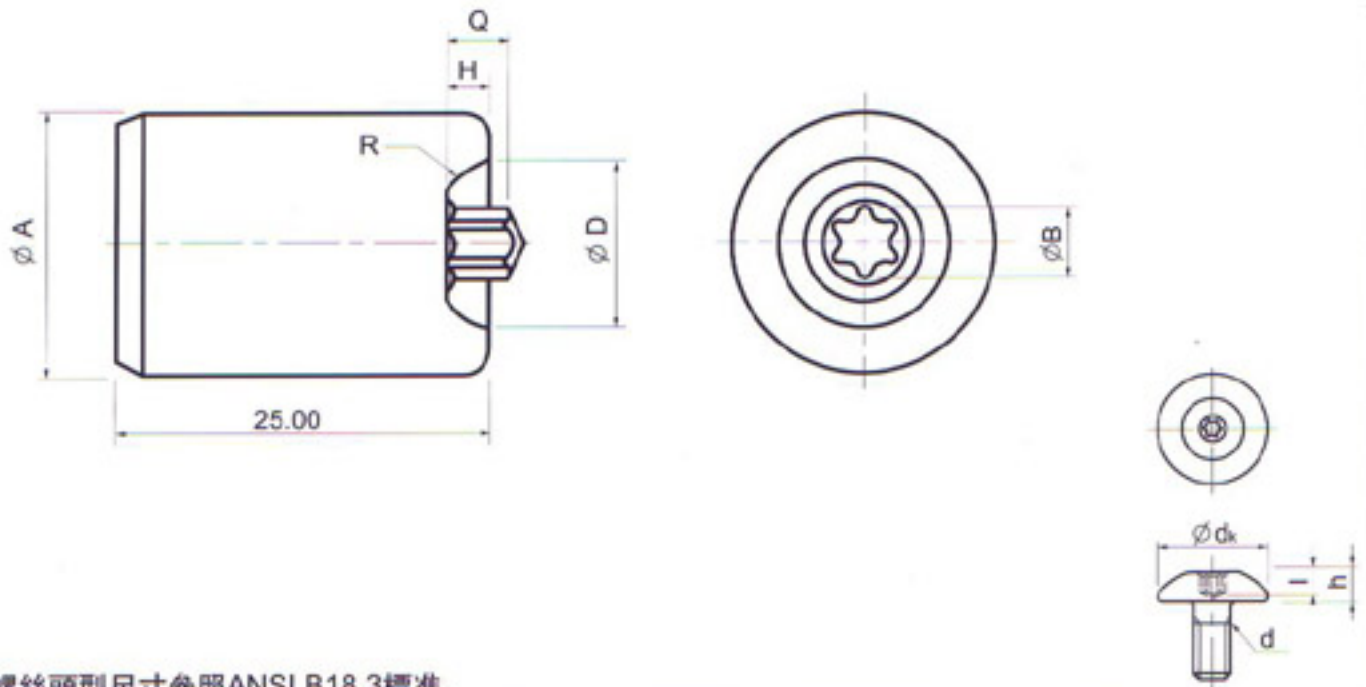

螺絲頭型尺寸參照ANSI B18.3標準.

| d (公稱規格) | SLX -LOBE (梅花槽型) | 沖頭尺寸 | | | | | | 螺絲尺寸 | | | | |
|-------------|------------------------|------|----------------------------------|----------------------------------|-------------------|----------------------------------|----|---------|---------|--------|--------|-------------------|
| | | B | D ^{+0.10} ₋₀ | H ⁺⁰ _{-0.10} | R _{REF.} | Q ^{+0.05} ₋₀ | A | dk MAX. | dk MIN. | h MAX. | h MIN. | l _{MIN.} |
| #2 | T6 | 1.75 | 4.27 | 0.80 | 2.80 | 0.66 | 12 | 4.17 | 3.91 | 1.17 | 0.97 | 0.56 |
| #4 | T8 | 2.39 | 5.51 | 1.10 | 3.30 | 0.90 | 12 | 5.41 | 5.11 | 1.50 | 1.30 | 0.76 |
| #6 | T10 | 2.82 | 6.75 | 1.40 | 4.00 | 1.05 | 12 | 6.65 | 6.35 | 1.85 | 1.60 | 0.89 |
| #8 | T15 | 3.35 | 8.12 | 1.76 | 4.60 | 1.20 | 14 | 7.92 | 7.57 | 2.21 | 1.96 | 1.02 |
| #10 | T25 | 4.52 | 9.37 | 2.00 | 5.20 | 1.47 | 18 | 9.17 | 8.81 | 2.57 | 2.31 | 1.27 |
| 1/4 | T27 | 5.08 | 11.30 | 2.70 | 6.20 | 1.72 | 18 | 11.10 | 10.64 | 3.35 | 3.10 | 1.52 |
| 5/16 | T40 | 6.76 | 14.10 | 3.46 | 7.60 | 2.50 | 23 | 13.90 | 13.39 | 4.22 | 3.86 | 2.29 |
| 3/8 | T45 | 7.92 | 16.87 | 4.20 | 9.10 | 2.90 | 30 | 16.67 | 16.15 | 5.05 | 4.70 | 2.67 |



BT6H (公制)

HEX. ISO 7380 BUTTON HEAD

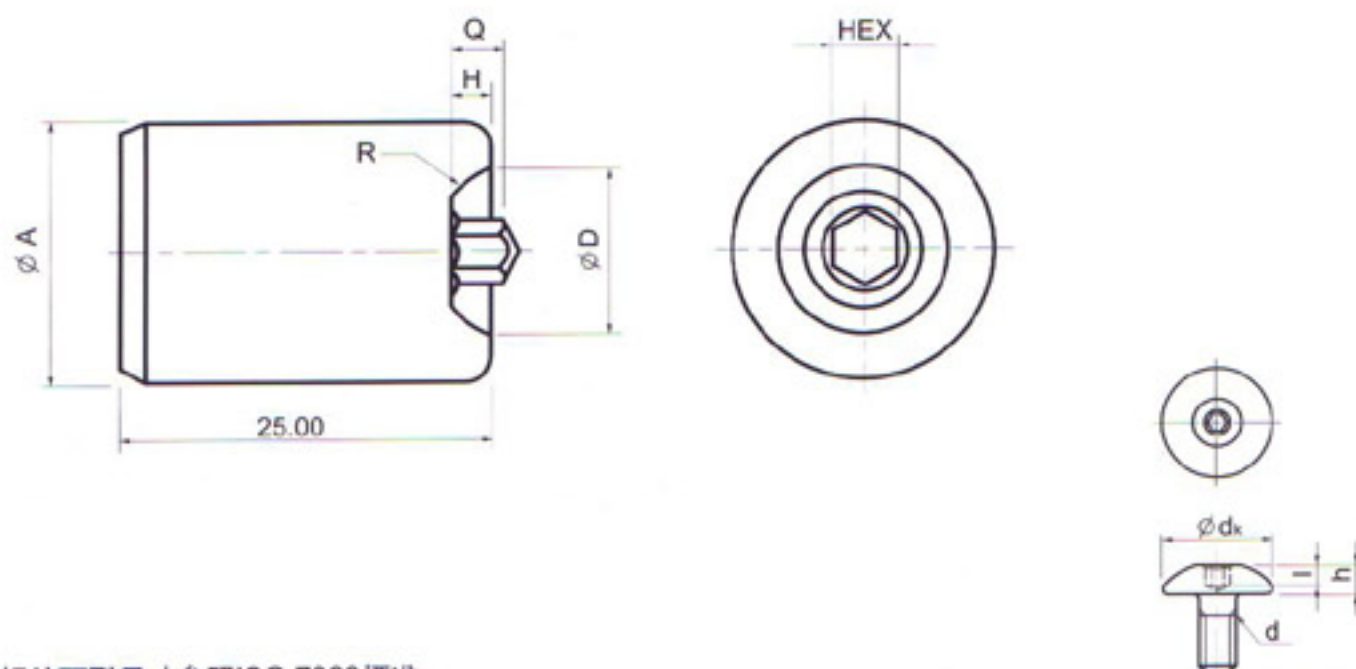

螺絲頭型尺寸參照ISO 7380標準.

| d (公稱規格) | 沖頭尺寸 | | | | | | 螺絲尺寸 | | | | |
|-------------|---------------|----------------------------------|----------------------------------|-------------------|----------------------------------|----|---------|---------|--------|--------|-------------------|
| | HEX (公稱對邊) | D ^{+0.10} ₋₀ | H ⁺⁰ _{-0.10} | R _{REF.} | Q ^{+0.05} ₋₀ | A | dk MAX. | dk MIN. | h MAX. | h MIN. | l _{MIN.} |
| M2.0 | 1.30 | 3.60 | 0.96 | 1.90 | 0.75 | 12 | 3.50 | 3.30 | 1.30 | 1.16 | 0.60 |
| M2.5 | 1.50 | 4.80 | 1.16 | 2.60 | 0.95 | 12 | 4.70 | 4.50 | 1.50 | 1.36 | 0.80 |
| M3.0 | 2.00 | 5.80 | 1.20 | 3.30 | 1.20 | 12 | 5.70 | 5.40 | 1.65 | 1.40 | 1.04 |
| M4.0 | 2.50 | 7.80 | 1.75 | 4.50 | 1.45 | 14 | 7.60 | 7.24 | 2.20 | 1.95 | 1.30 |
| M5.0 | 3.00 | 9.70 | 2.20 | 5.50 | 1.75 | 18 | 9.50 | 9.14 | 2.75 | 2.50 | 1.56 |
| M6.0 | 4.00 | 10.70 | 2.60 | 5.80 | 2.30 | 18 | 10.50 | 10.07 | 3.30 | 3.00 | 2.08 |
| M8.0 | 5.00 | 14.20 | 3.70 | 7.60 | 2.80 | 23 | 14.00 | 13.57 | 4.40 | 4.10 | 2.60 |
| M10.0 | 6.00 | 17.70 | 4.70 | 9.60 | 3.45 | 30 | 17.50 | 17.07 | 5.50 | 5.20 | 3.12 |



BT6H (英制)

HEX. ANSI BUTTON HEAD

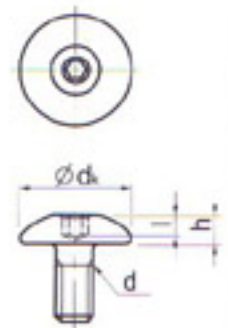
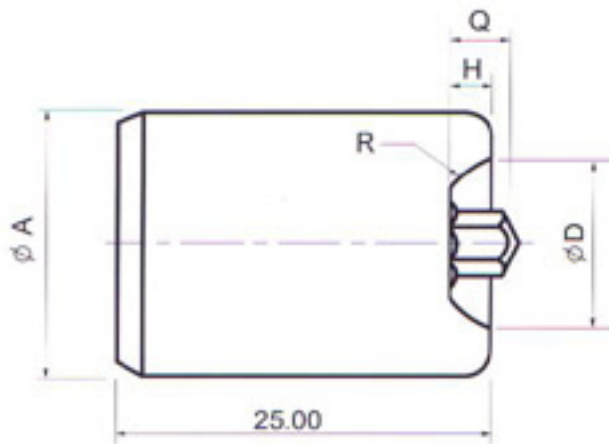

螺絲頭型尺寸參照ANSI B18.3標準.

| d (公稱規格) | HEX (六角標型) | 沖頭尺寸 | | | | | | 螺絲尺寸 | | | | |
|-------------|---------------|---------------|----------------------------------|----------------------------------|-------------------|----------------------------------|----|---------------------|---------------------|--------|--------|-------------------|
| | | HEX (公稱對邊) | D ^{+0.10} ₋₀ | H ⁺⁰ _{-0.10} | R _{REF.} | Q ^{+0.05} ₋₀ | A | d _K MAX. | d _K MIN. | h MAX. | h MIN. | l _{MIN.} |
| #2 | 0.05" | 1.27 | 4.27 | 0.80 | 2.70 | 0.81 | 12 | 4.17 | 3.91 | 1.17 | 0.97 | 0.71 |
| #4 | 1/16" | 1.57 | 5.51 | 1.10 | 3.40 | 1.00 | 12 | 5.41 | 5.11 | 1.50 | 1.30 | 0.89 |
| #6 | 5/64" | 1.98 | 6.75 | 1.40 | 4.10 | 1.22 | 12 | 6.65 | 6.35 | 1.85 | 1.60 | 1.12 |
| #8 | 3/32" | 2.39 | 8.12 | 1.76 | 4.80 | 1.42 | 14 | 7.92 | 7.57 | 2.21 | 1.96 | 1.32 |
| #10 | 1/8" | 3.18 | 9.37 | 2.00 | 5.40 | 1.93 | 18 | 9.17 | 8.81 | 2.57 | 2.31 | 1.78 |
| 1/4 | 5/32" | 3.96 | 11.30 | 2.70 | 6.20 | 2.36 | 18 | 11.10 | 10.64 | 3.35 | 3.10 | 2.21 |
| 5/16 | 3/16" | 4.78 | 14.10 | 3.46 | 7.80 | 2.82 | 23 | 13.90 | 13.39 | 4.22 | 3.86 | 2.67 |
| 3/8 | 7/32" | 5.56 | 16.87 | 4.20 | 9.40 | 3.25 | 30 | 16.67 | 16.15 | 5.05 | 4.70 | 3.10 |



PF6H

HEX. LCM PF. HEAD

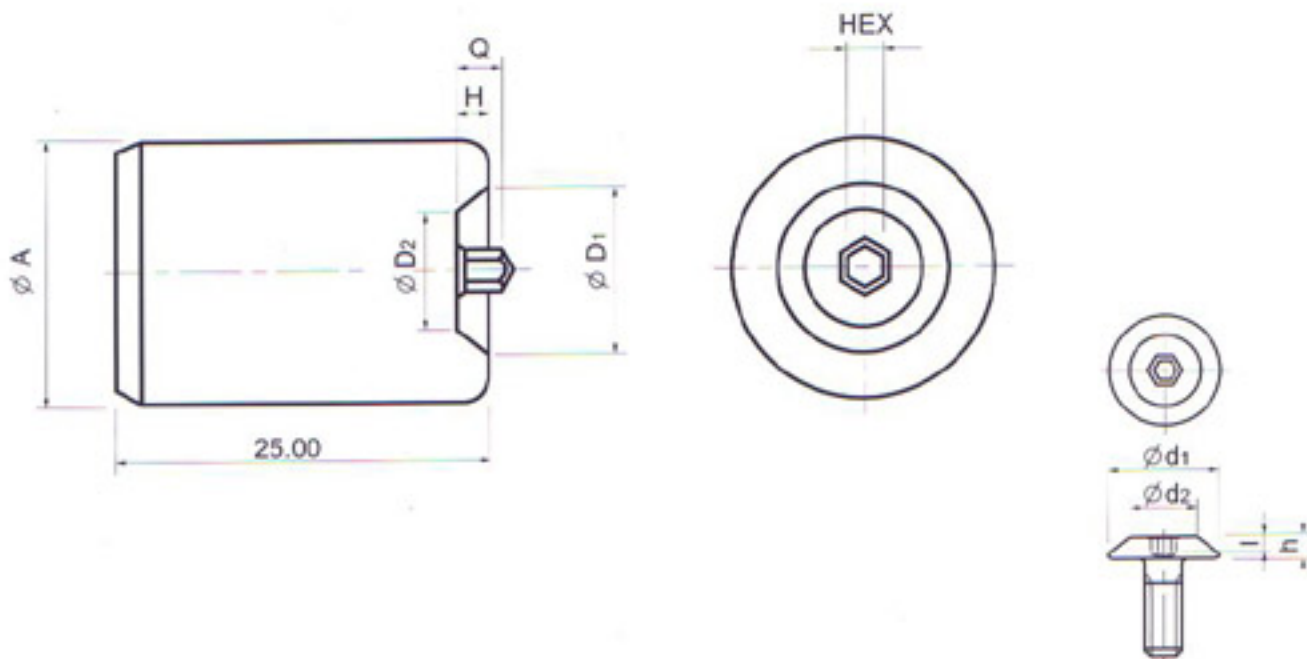

| d (公稱規格) | 沖頭尺寸 | | | | | | 螺絲尺寸 | | | |
|-------------|---------|----------|---------|---------------|--------|----|---------|----------|--------|--------|
| | D1 MAX. | D2 ±0.10 | H ±0.10 | HEX (公稱對邊) | Q MIN. | A | d1 MAX. | d2 ±0.10 | h MIN. | l MIN. |
| 7-10 | 10.30 | 7.00 | 1.00 | 4.00 | 2.50 | 14 | 10.00 | 7.00 | 2.60 | 2.30 |
| 8-11 | 11.30 | 8.00 | 1.00 | 4.00 | 2.50 | 18 | 11.00 | 8.00 | 2.60 | 2.30 |
| 9-12 | 12.30 | 9.00 | 1.00 | 4.00 | 2.50 | 18 | 12.00 | 9.00 | 2.60 | 2.30 |
| 10-13 | 13.30 | 10.00 | 1.00 | 4.00 | 2.50 | 18 | 13.00 | 10.00 | 3.00 | 2.30 |
| 11-14 | 14.30 | 11.00 | 1.00 | 4.00 | 2.50 | 18 | 14.00 | 11.00 | 3.00 | 2.30 |
| 12-15 | 15.50 | 12.00 | 1.20 | 4.00 | 2.50 | 18 | 15.00 | 12.00 | 3.00 | 2.30 |
| 13-16 | 16.50 | 13.00 | 1.20 | 5.00 | 3.00 | 23 | 16.00 | 13.00 | 3.40 | 2.80 |
| 14-17 | 17.50 | 14.00 | 1.20 | 5.00 | 3.00 | 23 | 17.00 | 14.00 | 3.40 | 2.80 |
| 15-18 | 18.50 | 15.00 | 1.20 | 6.00 | 3.30 | 23 | 18.00 | 15.00 | 3.80 | 3.10 |



| | |
|-------------|------------------------------|
| PFPH | PHILLIPS LCM PF. HEAD |
|-------------|------------------------------|

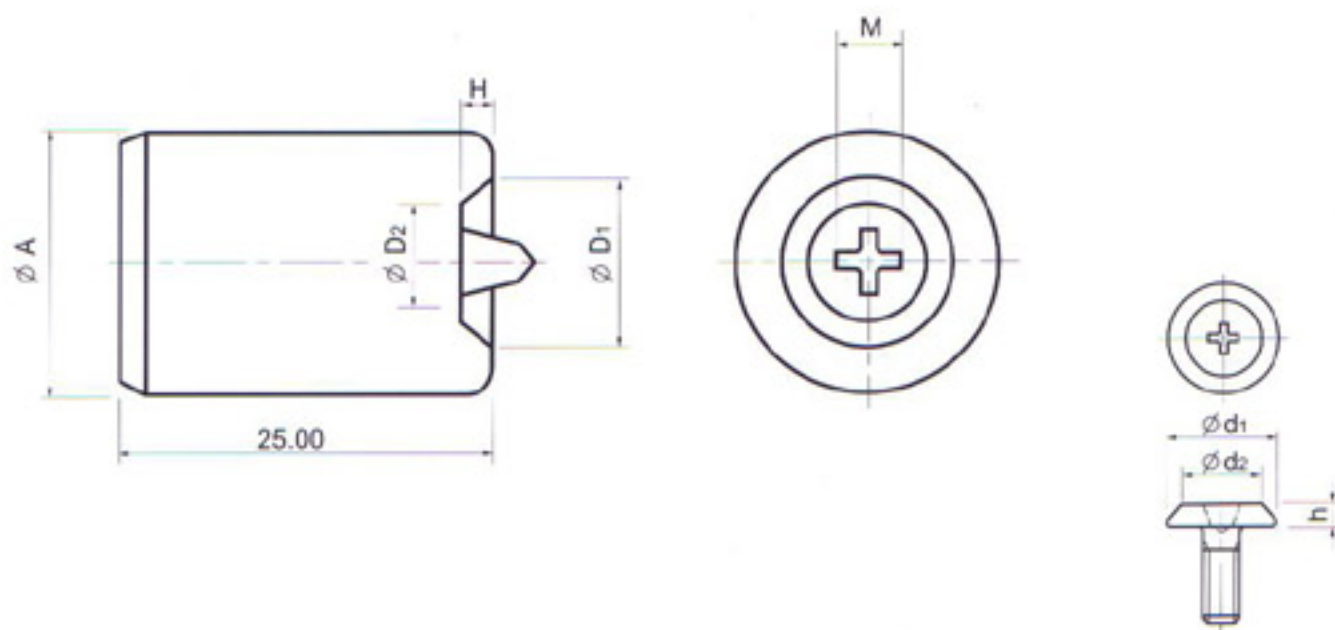

| d (公稱規格) | PHILLIPS (十字規格) | 冲頭尺寸 | | | | | PUNCH | 螺絲尺寸 | | |
|-------------|--------------------|--------|---------|----------|---------|----|-------|---------|----------|--------|
| | | M MAX. | D1 MAX. | D2 ±0.10 | H ±0.10 | A | | d1 MAX. | d2 ±0.10 | h MIN. |
| 7-10 | M40 | 4.40 | 10.30 | 7.00 | 1.00 | 14 | PH#2 | 10.00 | 7.00 | 2.60 |
| 8-11 | M45 | 4.80 | 11.30 | 8.00 | 1.00 | 18 | | 11.00 | 8.00 | 2.60 |
| 9-12 | M45 | 4.80 | 12.30 | 9.00 | 1.00 | 18 | | 12.00 | 9.00 | 2.60 |
| 10-13 | M50 | 5.00 | 13.30 | 10.00 | 1.00 | 18 | | 13.00 | 10.00 | 2.60 |
| 10-13 | M55 | 6.00 | 13.30 | 10.00 | 1.00 | 18 | PH#3 | 13.00 | 10.00 | 3.00 |
| 11-14 | M58 | 6.20 | 14.30 | 11.00 | 1.00 | 18 | | 14.00 | 11.00 | 3.00 |
| 12-15 | M58 | 6.20 | 15.50 | 12.00 | 1.20 | 18 | | 15.00 | 12.00 | 3.00 |
| 13-16 | M60 | 6.60 | 16.50 | 13.00 | 1.20 | 23 | | 16.00 | 13.00 | 3.40 |
| 14-17 | M60 | 6.60 | 17.50 | 14.00 | 1.20 | 23 | | 17.00 | 14.00 | 3.40 |
| 15-18 | M80 | 7.00 | 18.50 | 15.00 | 1.20 | 23 | | 18.00 | 15.00 | 3.80 |



IND-0 (公制)

IND ⊕ 圓台階 磨六角 冲棒

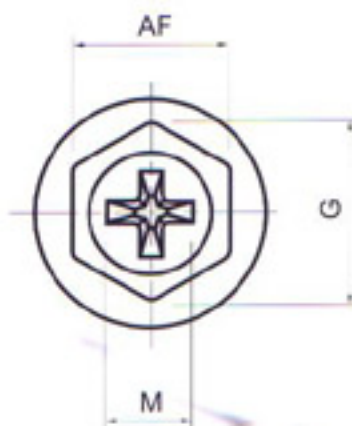
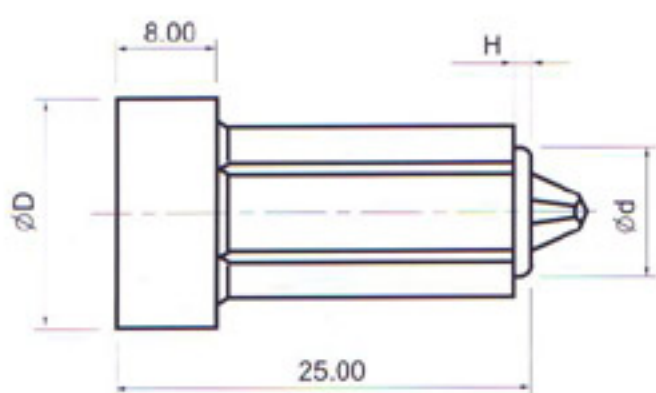

PHILLIPS JIS INDENTED HEX. WASHER HEAD

| 公稱規格 | 冲棒尺寸 | | | | | | | 螺絲尺寸 | | |
|------|--------------|--|---|--------------|---|-------------|-------|-------|-----------|-----------|
| | $D \pm 0.05$ | $AF \begin{smallmatrix} +0 \\ -0.02 \end{smallmatrix}$ | $d \begin{smallmatrix} +0 \\ -0.10 \end{smallmatrix}$ | $H \pm 0.05$ | $M \begin{smallmatrix} +0 \\ -0.10 \end{smallmatrix}$ | G (參考) | PUNCH | 公稱對邊 | F_{MAX} | F_{MIN} |
| M30 | 7.00 | 4.80 | 4.00 | 0.30 | 2.40 | 5.35 | PH#1 | 5.00 | 5.00 | 4.80 |
| M35 | 7.00 | 5.30 | 4.50 | 0.45 | 3.40 | 5.82 | PH#2 | 5.50 | 5.50 | 5.30 |
| M40 | 9.00 | 6.80 | 5.60 | 0.50 | 3.90 | 7.55 | | 7.00 | 7.00 | 6.80 |
| M45 | 9.00 | 6.80 | 5.60 | 0.55 | 4.10 | 7.55 | | 7.00 | 7.00 | 6.80 |
| M50 | 10.00 | 7.80 | 6.40 | 0.60 | 4.30 | 8.70 | | 8.00 | 8.00 | 7.80 |
| M60 | 12.00 | 9.80 | 8.40 | 0.70 | 6.10 | 10.90 | PH#3 | 10.00 | 10.00 | 9.80 |
| M80 | 14.00 | 11.78 | 10.00 | 1.00 | 7.10 | 13.10 | | 12.00 | 12.00 | 11.75 |



IND-0 (英制)

IND ⊕ 圓台階 磨六角 沖棒

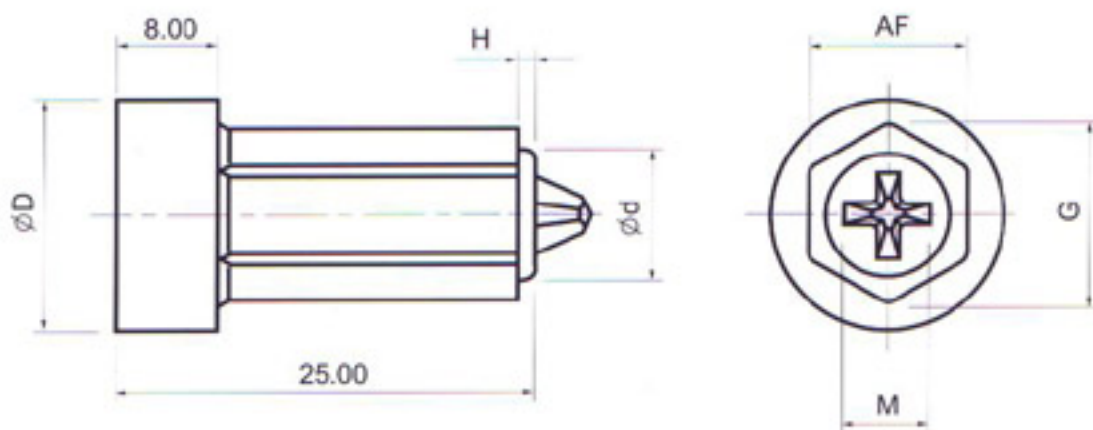

PHILLIPS ANSI INDENTED HEX. WASHER HEAD

| 公稱規格 | 沖棒尺寸 | | | | | | | 螺絲尺寸 | | |
|------|--------------|-------------------|------------------|--------------|------------------|-----------|-------|-------|--------|--------|
| | $D \pm 0.05$ | $AF^{+0}_{-0.02}$ | $d^{+0}_{-0.10}$ | $H \pm 0.05$ | $M^{+0}_{-0.10}$ | G (參考) | PUNCH | 公稱對邊 | F MAX. | F MIN. |
| #4 | 7.00 | 4.60 | 3.80 | 0.40 | 2.20 | 5.10 | PH#1 | 3/16" | 4.75 | 4.60 |
| #5 | 7.00 | 4.60 | 3.80 | 0.50 | 2.40 | 5.10 | | 3/16" | 4.75 | 4.60 |
| #6 | 8.00 | 6.20 | 5.10 | 0.50 | 3.40 | 6.86 | PH#2 | 1/4" | 6.35 | 6.20 |
| #8 | 8.00 | 6.20 | 5.10 | 0.60 | 3.70 | 6.86 | | 1/4" | 6.35 | 6.20 |
| #10 | 10.00 | 7.78 | 6.40 | 0.60 | 4.30 | 8.68 | | 5/16" | 7.92 | 7.75 |
| #12 | 10.00 | 7.78 | 6.40 | 0.70 | 4.55 | 8.68 | | 5/16" | 7.92 | 7.75 |
| 1/4 | 12.00 | 9.35 | 8.00 | 0.80 | 5.80 | 10.50 | PH#3 | 3/8" | 9.52 | 9.32 |



IND-2 (公制)

IND ⊕ ⊖ 圓台階 磨六角 冲棒

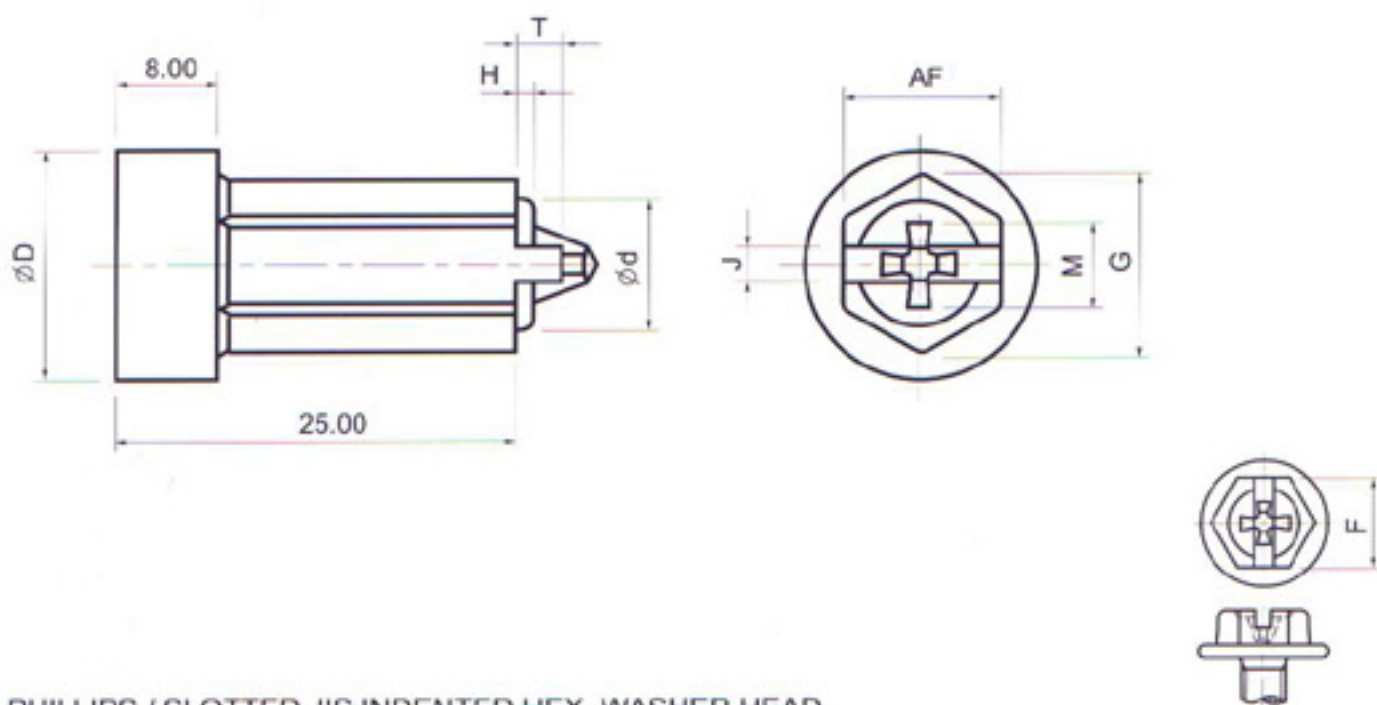

PHILLIPS / SLOTTED JIS INDENTED HEX. WASHER HEAD

| 公稱規格 | 冲棒尺寸 | | | | | | | | | 螺絲尺寸 | | |
|------|--------------|-------------------|------------------|--------------|------------------|--------|------------------|--------------|-------|-------|--------|--------|
| | $D \pm 0.05$ | $AF^{+0}_{-0.02}$ | $d^{+0}_{-0.10}$ | $H \pm 0.05$ | $M^{+0}_{-0.10}$ | G (參考) | $J^{+0.05}_{-0}$ | $T \pm 0.05$ | PUNCH | 公稱對邊 | F MAX. | F MIN. |
| M30 | 7.00 | 4.80 | 4.00 | 0.30 | 2.40 | 5.35 | 0.85 | 0.80 | PH#2 | 5.00 | 5.00 | 4.80 |
| M35 | 7.00 | 5.30 | 4.50 | 0.45 | 3.40 | 5.82 | 1.10 | 1.10 | | 5.50 | 5.50 | 5.30 |
| M40 | 9.00 | 6.80 | 5.60 | 0.50 | 3.90 | 7.55 | 1.20 | 1.40 | | 7.00 | 7.00 | 6.80 |
| M45 | 9.00 | 6.80 | 5.60 | 0.55 | 4.30 | 7.55 | 1.20 | 1.50 | | 7.00 | 7.00 | 6.80 |
| M50 | 10.00 | 7.80 | 6.40 | 0.60 | 4.70 | 8.70 | 1.30 | 1.60 | | 8.00 | 8.00 | 7.80 |
| M60 | 12.00 | 9.80 | 8.40 | 0.70 | 6.10 | 10.90 | 1.50 | 2.10 | PH#3 | 10.00 | 10.00 | 9.80 |
| M80 | 14.00 | 11.78 | 10.00 | 1.00 | 7.10 | 13.10 | 1.70 | 2.50 | | 12.00 | 12.00 | 11.75 |



IND-2 (英制)

IND ⊕ ⊖ 圓台階 磨六角 冲棒

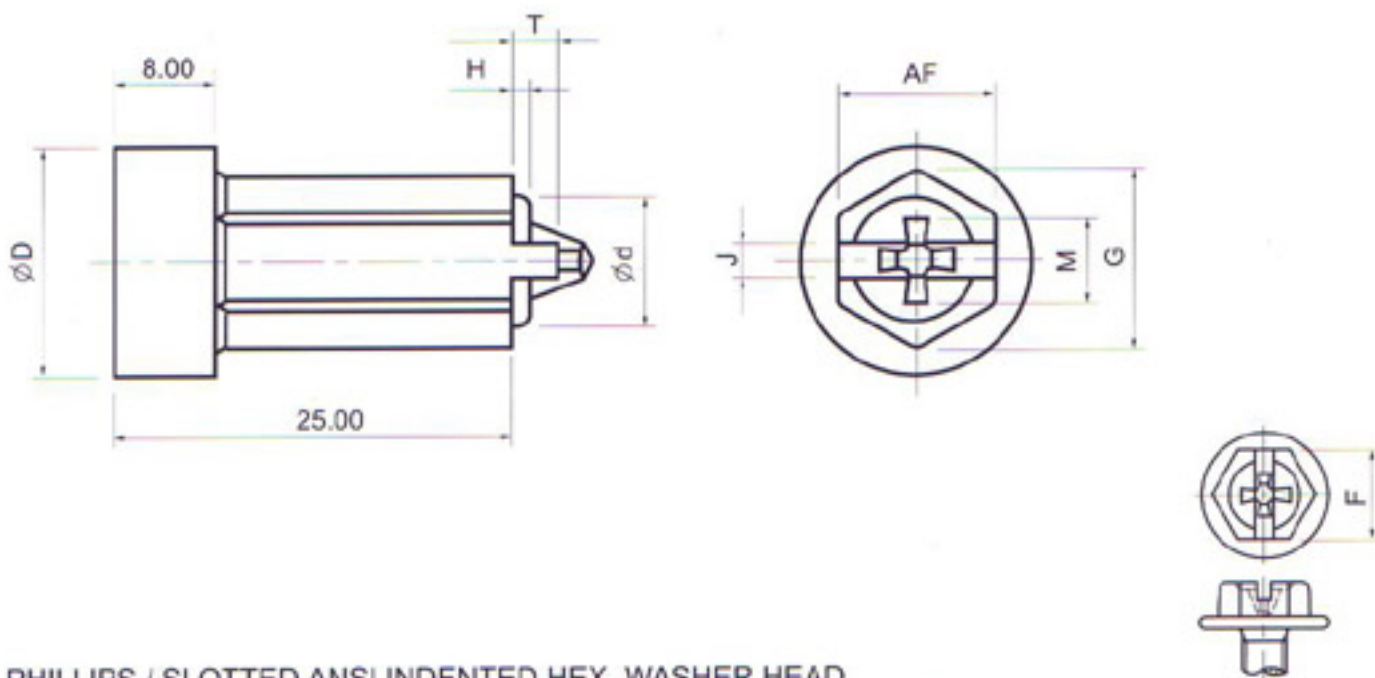

PHILLIPS / SLOTTED ANSI INDENTED HEX. WASHER HEAD

| 公稱規格 | 冲棒尺寸 | | | | | | | | | 螺絲尺寸 | | | | |
|------|---------|-----------------------------------|----------------------------------|---------|----------------------------------|--------|----------------------------------|---------|-------|-------|--------|--------|-------|------|
| | D ±0.05 | AF ⁺⁰ _{-0.02} | d ⁺⁰ _{-0.10} | H ±0.05 | M ⁺⁰ _{-0.10} | G (參考) | J ^{+0.05} ₋₀ | T ±0.05 | PUNCH | 公稱對邊 | F MAX. | F MIN. | | |
| #4 | 7.00 | 4.60 | 3.80 | 0.40 | 2.50 | 5.10 | 0.85 | 0.80 | PH#1 | 3/16" | 4.75 | 4.60 | | |
| #6 | 8.00 | 6.20 | 5.20 | 0.50 | 4.00 | 6.86 | 1.10 | 1.10 | | PH#2 | 1/4" | 6.35 | 6.20 | |
| #7 | 8.00 | 6.20 | 5.20 | 0.50 | 4.20 | 6.86 | 1.10 | 1.30 | | | PH#3 | 1/4" | 6.35 | 6.20 |
| #8 | 8.00 | 6.20 | 5.20 | 0.60 | 4.40 | 6.86 | 1.25 | 1.60 | | | | 5/16" | 7.92 | 7.75 |
| #10 | 10.00 | 7.78 | 6.40 | 0.70 | 4.70 | 8.68 | 1.40 | 1.75 | | | | | 5/16" | 7.92 |
| #12 | 10.00 | 7.78 | 6.40 | 0.90 | 5.00 | 8.68 | 1.60 | 2.30 | | | | 3/8" | | 9.52 |
| #14 | 12.00 | 9.35 | 8.00 | 1.00 | 5.80 | 10.50 | 1.75 | 2.45 | | | 3/8" | | 9.52 | 9.32 |
| 1/4 | 12.00 | 9.35 | 8.00 | 1.00 | 5.80 | 10.50 | 1.75 | 2.45 | | | | | | |



IND-4 (公制)

IND ⊖ 圓台階 磨六角 冲棒

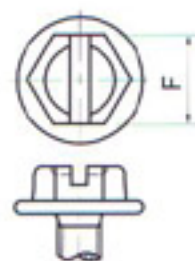
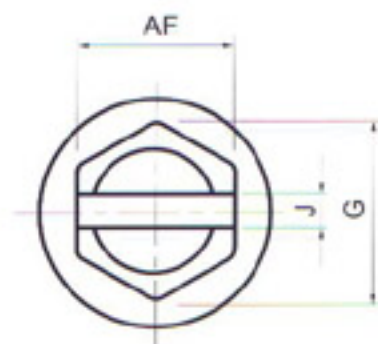
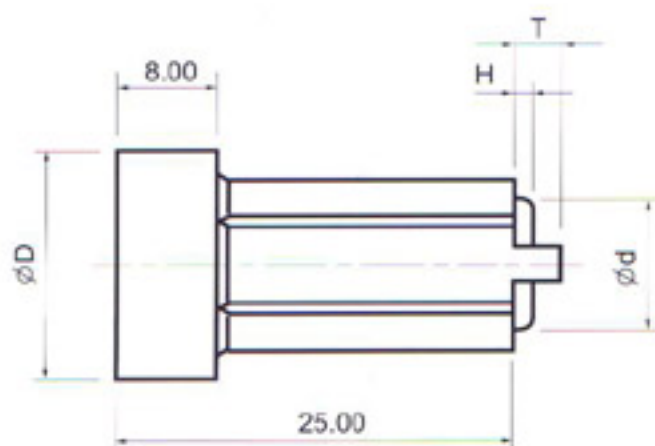

SLOTTED JIS INDENTED HEX. WASHER HEAD

| 公稱規格 | 冲棒尺寸 | | | | | | | 螺絲尺寸 | | |
|------|--------------|-------------------|------------------|--------------|--------|------------------|--------------|-------|--------|--------|
| | $D \pm 0.05$ | $AF^{+0}_{-0.02}$ | $d^{+0}_{-0.10}$ | $H \pm 0.05$ | G (參考) | $J^{+0.05}_{-0}$ | $T \pm 0.05$ | 公稱對邊 | F MAX. | F MIN. |
| M30 | 7.00 | 4.80 | 4.00 | 0.40 | 5.35 | 0.85 | 0.80 | 5.00 | 5.00 | 4.80 |
| M35 | 7.00 | 5.30 | 4.50 | 0.50 | 5.82 | 1.00 | 1.10 | 5.50 | 5.50 | 5.30 |
| M40 | 9.00 | 6.80 | 5.80 | 0.60 | 7.55 | 1.20 | 1.40 | 7.00 | 7.00 | 6.80 |
| M45 | 9.00 | 6.80 | 5.80 | 0.60 | 7.55 | 1.30 | 1.50 | 7.00 | 7.00 | 6.80 |
| M50 | 10.00 | 7.80 | 6.70 | 0.80 | 8.70 | 1.40 | 1.70 | 8.00 | 8.00 | 7.80 |
| M60 | 12.00 | 9.80 | 8.50 | 1.00 | 10.90 | 1.60 | 2.30 | 10.00 | 10.00 | 9.80 |
| M80 | 14.00 | 11.78 | 10.00 | 1.20 | 13.10 | 1.70 | 2.50 | 12.00 | 12.00 | 11.75 |



IND-4 (英制)

IND ⊖ 圓台階 磨六角 沖棒

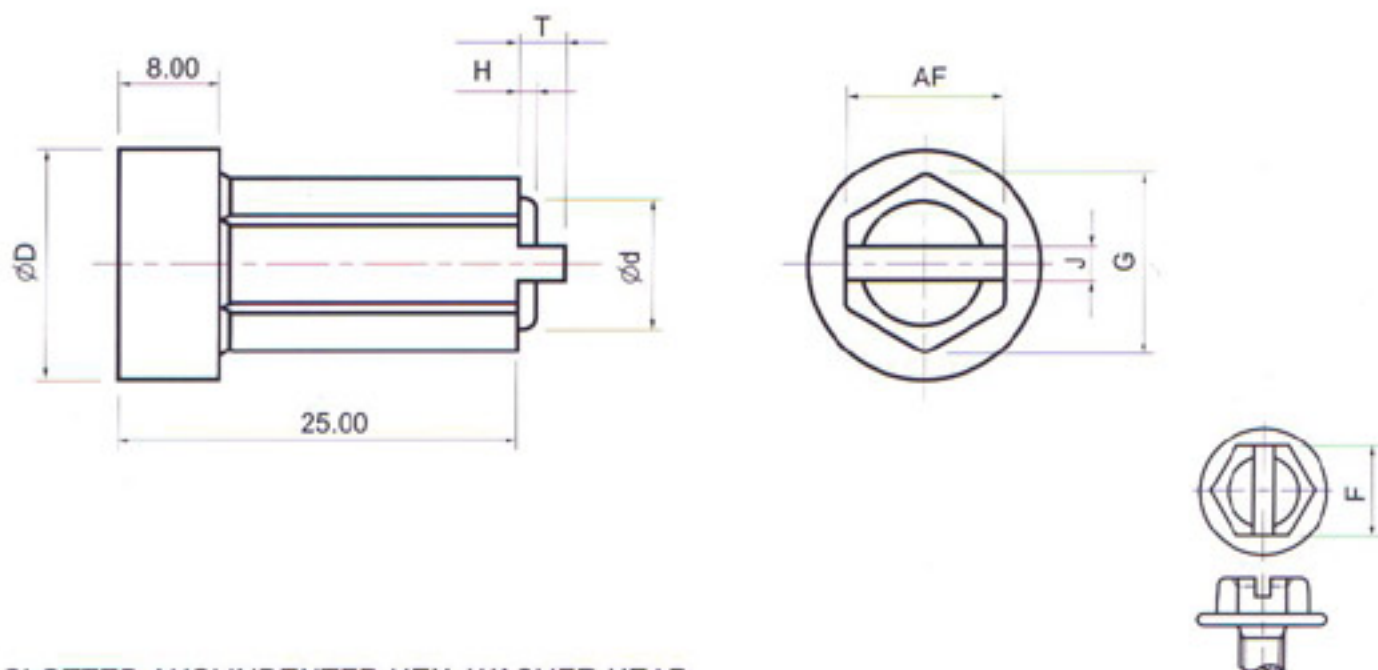

SLOTTED ANSI INDENTED HEX. WASHER HEAD

| 公稱規格 | 沖棒尺寸 | | | | | | | 螺絲尺寸 | | |
|------|--------------|--|---|--------------|-------------|---|--------------|-------|-----------|-----------|
| | $D \pm 0.05$ | $AF \begin{smallmatrix} +0 \\ -0.02 \end{smallmatrix}$ | $d \begin{smallmatrix} +0 \\ -0.10 \end{smallmatrix}$ | $H \pm 0.05$ | G (參考) | $J \begin{smallmatrix} +0.05 \\ -0 \end{smallmatrix}$ | $T \pm 0.05$ | 公稱對邊 | F_{MAX} | F_{MIN} |
| #4 | 7.00 | 4.60 | 4.00 | 0.50 | 5.10 | 0.85 | 0.80 | 3/16" | 4.75 | 4.60 |
| #6 | 8.00 | 6.20 | 5.50 | 0.60 | 6.86 | 1.10 | 1.10 | 1/4" | 6.35 | 6.20 |
| #7 | 8.00 | 6.20 | 5.50 | 0.60 | 6.86 | 1.10 | 1.30 | 1/4" | 6.35 | 6.20 |
| #8 | 8.00 | 6.20 | 5.50 | 0.65 | 6.86 | 1.25 | 1.60 | 1/4" | 6.35 | 6.20 |
| #10 | 10.00 | 7.78 | 6.80 | 0.90 | 8.68 | 1.40 | 1.75 | 5/16" | 7.92 | 7.75 |
| #12 | 10.00 | 7.78 | 6.80 | 1.00 | 8.68 | 1.60 | 2.30 | 5/16" | 7.92 | 7.75 |
| #14 | 12.00 | 9.35 | 8.30 | 1.00 | 10.50 | 1.75 | 2.45 | 3/8" | 9.52 | 9.32 |
| 1/4 | 12.00 | 9.35 | 8.30 | 1.00 | 10.50 | 1.75 | 2.45 | 3/8" | 9.52 | 9.32 |



牙板 THREAD ROLLING DIE

| MACHINE TYPE | S | H | L1 (FIXED) | L2 (MOVING) |
|--------------|------|-------------------------|------------|-------------|
| 0 | 19 | 25 | 51 | 64 |
| 3/16 | 25 | 25, 38, 55 | 75 | 90 |
| 1/4 | 25 | 25, 40, 55, 65, 80 | 100 | 115 |
| 5/16 | 25 | 25, 40, 55, 65, 80, 105 | 127 | 140 |
| 3/8 | 25 | 25, 40, 55, 65, 80, 105 | 150 | 165 |
| 1/2 | 35 | 55, 80, 105, 125, 150 | 190 | 215 |
| 3/4 | 38 | 55, 80, 105, 125, 150 | 230 | 265 |
| 003 | 15 | 20 | 45 | 55 |
| 004 | 20 | 25 | 65 | 80 |
| 4R | 20 | 25 | 60 | 70 |
| 6R | 25 | 25, 30, 40, 55 | 90 | 105 |
| 8R | 25 | 25, 30, 40, 55, 65 | 108 | 127 |
| 250 | 25 | 25, 40, 55 | 110 | 125 |
| DR125 | 20.8 | 25, 40 | 73.3 | 86.2 (5°) |
| DR200 | 20.8 | 25, 40, 53 | 92.3 | 105.2 (5°) |
| DR250 | 23.8 | 25, 40, 54 | 112 | 131.2 (5°) |

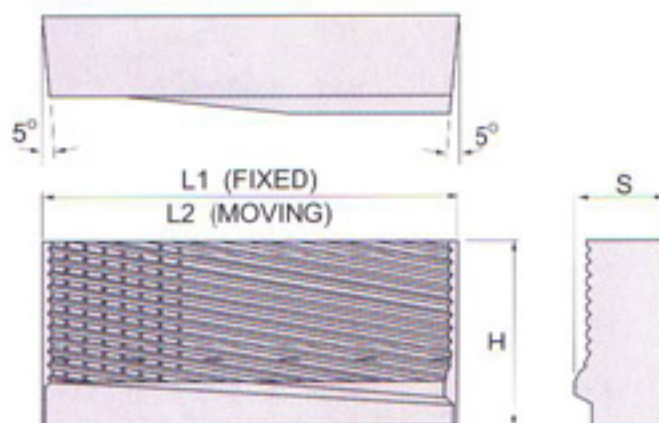
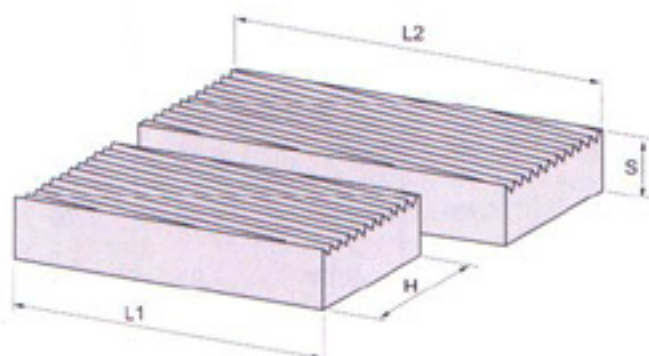

機械螺絲規格表 MACHINE SCREW SIZE

| BSW MACHINE SCREW 2A Q(55°) 韋氏牙規格 | | | | | | |
|--------------------------------------|------------|--------------|--------------|--------------|--------------|------------------|
| 規格 SIZE | 牙數 P(T) | 外徑(D) | | 螺造徑(d) | | (B) 牙山 高度數 |
| | | 最大 (MAX.) | 最小 (MIN.) | 最大 (MAX.) | 最小 (MIN.) | |
| 1/16 | 60 | 1.560 | 1.470 | 1.29 | 1.27 | 0.235 |
| 3/32 | 48 | 2.361 | 2.155 | 2.01 | 1.99 | 0.258 |
| 1/8 | 40 | 3.155 | 3.045 | 2.72 | 2.70 | 0.390 |
| 5/32 | 32 | 3.945 | 3.795 | 3.40 | 3.38 | 0.480 |
| 3/16 | 24 | 4.742 | 4.592 | 4.03 | 4.00 | 0.852 |
| 1/4 | 20 | 6.330 | 6.160 | 5.48 | 5.45 | 0.780 |
| 5/16 | 18 | 7.910 | 7.720 | 6.97 | 6.94 | 0.860 |
| 3/8 | 16 | 9.500 | 9.310 | 8.44 | 8.40 | 0.985 |
| 7/16 | 14 | 11.082 | 10.892 | 9.88 | 9.84 | 1.127 |
| 1/2 | 12 | 12.670 | 12.460 | 11.27 | 11.22 | 1.319 |
| 9/16 | 12 | 14.258 | 14.047 | 12.86 | 12.81 | 1.319 |
| 5/8 | 11 | 15.848 | 15.605 | 14.33 | 14.27 | 1.426 |
| 3/4 | 10 | 19.020 | 18.780 | 17.34 | 17.28 | 1.590 |
| 7/8 | 9 | 22.195 | 21.935 | 20.32 | 20.28 | 1.765 |
| 1" | 8 | 25.370 | 25.110 | 23.27 | 23.23 | 1.990 |

| M/M MACHINE SCREW 2A Q(60°) 米厘牙規格(粗牙) | | | | | | |
|--|---------|--------------|--------------|--------------|--------------|------------------|
| 規格 SIZE | 牙距 P | 外徑(D) | | 螺造徑(d) | | (B) 牙山 高度數 |
| | | 最大 (MAX.) | 最小 (MIN.) | 最大 (MAX.) | 最小 (MIN.) | |
| M2 | 0.4 | 1.980 | 1.890 | 1.70 | 1.67 | 0.250 |
| 2.3 | 0.4 | 2.280 | 2.190 | 2.00 | 1.97 | 0.250 |
| 2.6 | 0.45 | 2.580 | 2.480 | 2.26 | 2.23 | 0.261 |
| 3 | 0.5 | 2.980 | 2.870 | 2.63 | 2.60 | 0.313 |
| 3.5 | 0.6 | 3.470 | 3.360 | 3.06 | 3.03 | 0.375 |
| 4 | 0.7 | 3.978 | 3.838 | 3.49 | 3.45 | 0.438 |
| 4.5 | 0.75 | 4.470 | 4.340 | 3.96 | 3.92 | 0.468 |
| 5 | 0.8 | 4.976 | 4.826 | 4.43 | 4.38 | 0.500 |
| 6 | 1.0 | 5.970 | 5.820 | 5.30 | 5.25 | 0.625 |
| 7 | 1.0 | 6.970 | 6.820 | 6.30 | 6.25 | 0.625 |
| 8 | 1.25 | 7.960 | 7.790 | 7.12 | 7.07 | 0.782 |
| 9 | 1.25 | 8.960 | 8.790 | 8.12 | 8.07 | 0.782 |
| 10 | 1.5 | 9.960 | 9.770 | 8.97 | 8.91 | 0.940 |
| 11 | 1.5 | 10.968 | 10.732 | 9.97 | 9.91 | 0.940 |
| 12 | 1.75 | 11.950 | 11.760 | 10.79 | 10.73 | 1.094 |
| 14 | 2.0 | 13.950 | 13.740 | 12.63 | 12.56 | 1.264 |
| 16 | 2.0 | 15.950 | 15.740 | 14.63 | 14.56 | 1.264 |
| 18 | 2.5 | 17.950 | 17.710 | 16.31 | 16.23 | 1.560 |
| 20 | 2.5 | 19.950 | 19.710 | 18.31 | 18.23 | 1.560 |
| 22 | 2.5 | 21.950 | 21.710 | 20.31 | 20.23 | 1.560 |
| 24 | 3.0 | 23.940 | 23.680 | 21.98 | 21.90 | 1.870 |
| 27 | 3.0 | 26.940 | 26.680 | 24.98 | 24.89 | 1.870 |
| 30 | 3.5 | 29.940 | 29.660 | 27.66 | 27.56 | 2.190 |
| 33 | 3.5 | 32.940 | 32.660 | 30.65 | 30.56 | 2.190 |
| 36 | 4.0 | 35.930 | 35.630 | 33.33 | 33.23 | 2.500 |

| M/M MACHINE SCREW 2A Q(60°) 米厘牙規格(細牙) | | | | | | |
|--|---------|--------------|--------------|--------------|--------------|------------------|
| 規格 SIZE | 牙距 P | 外徑(D) | | 螺造徑(d) | | (B) 牙山 高度數 |
| | | 最大 (MAX.) | 最小 (MIN.) | 最大 (MAX.) | 最小 (MIN.) | |
| M4 | 0.5 | 3.980 | 3.874 | 3.61 | 3.57 | 0.313 |
| 4.5 | 0.5 | 4.480 | 4.374 | 4.11 | 4.07 | 0.313 |
| 5 | 0.5 | 4.980 | 4.874 | 4.61 | 4.57 | 0.313 |
| 6 | 0.75 | 5.978 | 5.838 | 5.45 | 5.41 | 0.468 |
| 7 | 0.75 | 6.978 | 6.838 | 6.45 | 6.41 | 0.468 |
| 8 | 1.0 | 7.974 | 7.794 | 7.29 | 7.24 | 0.625 |
| 9 | 1.0 | 8.974 | 8.794 | 8.29 | 8.24 | 0.625 |
| 10 | 1.25 | 9.972 | 9.760 | 9.12 | 9.07 | 0.782 |
| 10 | 1.0 | 9.974 | 9.794 | 9.28 | 9.23 | 0.625 |
| 12 | 1.25 | 11.972 | 11.780 | 11.12 | 11.07 | 0.782 |
| 12 | 1.5 | 11.968 | 11.732 | 10.95 | 10.89 | 0.940 |
| 14 | 1.5 | 13.968 | 13.732 | 12.95 | 12.89 | 0.940 |
| 16 | 1.5 | 15.968 | 15.732 | 14.95 | 14.89 | 0.940 |
| 18 | 2.0 | 17.962 | 17.682 | 16.62 | 16.54 | 1.264 |
| 18 | 1.5 | 17.968 | 17.732 | 16.93 | 16.86 | 0.940 |
| 20 | 2.0 | 19.962 | 19.682 | 18.62 | 18.54 | 1.264 |
| 20 | 1.5 | 19.968 | 19.732 | 18.92 | 18.85 | 0.940 |
| 22 | 1.5 | 21.968 | 21.732 | 20.92 | 20.85 | 0.940 |
| 24 | 1.5 | 23.968 | 23.732 | 22.92 | 22.85 | 0.940 |
| 26 | 1.5 | 25.968 | 25.732 | 24.93 | 24.85 | 0.940 |
| 27 | 1.5 | 26.968 | 26.732 | 25.93 | 25.85 | 0.940 |
| 28 | 1.5 | 27.968 | 27.732 | 26.93 | 26.85 | 0.940 |
| 30 | 1.5 | 29.968 | 29.732 | 28.93 | 28.85 | 0.940 |
| 32 | 1.5 | 31.968 | 31.732 | 30.93 | 30.85 | 0.940 |
| 33 | 1.5 | 32.968 | 32.732 | 31.93 | 31.85 | 0.940 |

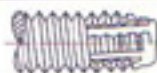

| BA MACHINE SCREW 2A Q(47.5°) BA 規 格 | | | | | | |
|--|---------|--------------|--------------|--------------|--------------|------------------|
| 規格 SIZE | 牙距 P | 外徑(D) | | 螺造徑(d) | | (B) 牙山 高度數 |
| | | 最大 (MAX.) | 最小 (MIN.) | 最大 (MAX.) | 最小 (MIN.) | |
| OBA | 1.0 | 5.970 | 5.820 | 5.320 | 5.220 | 0.625 |
| 1BA | 0.9 | 5.270 | 5.120 | 4.685 | 4.580 | 0.562 |
| 2BA | 0.81 | 4.676 | 4.526 | 4.150 | 4.016 | 0.518 |
| 3BA | 0.73 | 4.078 | 3.938 | 3.604 | 3.479 | 0.466 |
| 4BA | 0.66 | 3.570 | 3.460 | 3.141 | 3.045 | 0.422 |
| 5BA | 0.59 | 3.180 | 3.050 | 2.797 | 2.779 | 0.477 |
| 6BA | 0.53 | 2.780 | 2.660 | 2.436 | 2.327 | 0.438 |
| 8BA | 0.43 | 1.810 | 1.720 | 1.531 | 1.450 | 0.275 |

| SM MACHINE SCREW 2A Q(60°) SM 針 車 用 規 格 | | | | | | |
|--|------------|--------------|--------------|--------------|--------------|------------------|
| 規格 SIZE | 牙數 P(T) | 外徑(D) | | 螺造徑(d) | | (B) 牙山 高度數 |
| | | 最大 (MAX.) | 最小 (MIN.) | 最大 (MAX.) | 最小 (MIN.) | |
| 5/64 | 64 | 1.964 | 1.867 | 1.69 | 1.68 | 0.230 |
| 3/32 | 56 | 2.361 | 2.267 | 2.06 | 2.04 | 0.264 |
| 1/8 | 48 | 3.155 | 3.041 | 2.80 | 2.78 | 0.308 |
| 1/8 | 44 | 3.155 | 3.041 | 2.77 | 2.75 | 0.334 |
| 1/8 | 40 | 3.155 | 3.041 | 2.73 | 2.71 | 0.370 |
| 9/64 | 40 | 3.542 | 3.432 | 3.13 | 3.10 | 0.370 |
| 11/64 | 40 | 4.336 | 4.226 | 3.92 | 3.89 | 0.370 |
| 11/64 | 32 | 4.336 | 4.226 | 3.81 | 3.79 | 0.470 |
| 3/16 | 40 | 4.732 | 4.602 | 4.31 | 4.28 | 0.470 |
| 3/16 | 32 | 4.732 | 4.602 | 4.22 | 4.19 | 0.470 |
| 3/16 | 28 | 4.732 | 4.602 | 4.14 | 4.11 | 0.542 |
| 3/16 | 24 | 4.732 | 4.602 | 4.04 | 4.01 | 0.640 |
| 13/64 | 32 | 5.126 | 4.976 | 4.60 | 4.57 | 0.470 |
| 7/32 | 32 | 5.526 | 5.376 | 5.01 | 4.98 | 0.470 |
| 15/64 | 28 | 5.923 | 5.773 | 5.32 | 5.29 | 0.542 |
| 1/4 | 40 | 6.330 | 6.160 | 5.90 | 5.87 | 0.370 |
| 1/4 | 28 | 6.330 | 6.160 | 5.72 | 5.69 | 0.542 |
| 1/4 | 24 | 6.330 | 6.160 | 5.62 | 5.59 | 0.640 |
| 9/32 | 28 | 7.114 | 6.964 | 6.51 | 6.48 | 0.540 |
| 9/32 | 20 | 7.114 | 6.964 | 6.28 | 6.25 | 0.774 |
| 5/16 | 24 | 7.910 | 7.727 | 7.21 | 7.18 | 0.640 |
| 5/16 | 18 | 7.910 | 7.727 | 6.97 | 6.94 | 0.863 |

| UNC MACHINE SCREW 2A Q(60°) 美 國 粗 牙 規 格 | | | | | | |
|--|------------|--------------|--------------|--------------|--------------|------------------|
| 規格 SIZE | 牙數 P(T) | 外徑(D) | | 螺造徑(d) | | (B) 牙山 高度數 |
| | | 最大 (MAX.) | 最小 (MIN.) | 最大 (MAX.) | 最小 (MIN.) | |
| NO. 1 | 64 | 1.838 | 1.743 | 1.57 | 1.54 | 0.235 |
| NO. 2 | 56 | 2.169 | 2.066 | 1.86 | 1.84 | 0.268 |
| NO. 3 | 48 | 2.496 | 2.383 | 2.14 | 2.11 | 0.310 |
| NO. 4 | 40 | 2.824 | 2.695 | 2.40 | 2.36 | 0.380 |
| NO. 5 | 40 | 3.154 | 3.026 | 2.72 | 2.69 | 0.380 |
| NO. 6 | 32 | 3.484 | 3.333 | 2.95 | 2.91 | 0.478 |
| NO. 8 | 32 | 4.142 | 3.991 | 3.60 | 3.57 | 0.478 |
| NO. 10 | 24 | 4.800 | 4.618 | 4.09 | 4.05 | 0.640 |
| NO. 12 | 24 | 5.461 | 5.279 | 4.75 | 4.70 | 0.640 |
| 1/4 | 20 | 6.322 | 6.117 | 5.50 | 5.45 | 0.760 |
| 5/16 | 18 | 7.907 | 7.687 | 6.98 | 6.93 | 0.849 |
| 3/8 | 16 | 9.491 | 9.254 | 8.45 | 8.40 | 0.947 |
| 7/16 | 14 | 11.076 | 10.816 | 9.89 | 9.83 | 1.086 |
| 1/2 | 13 | 12.661 | 12.386 | 11.39 | 11.32 | 1.168 |
| 9/16 | 12 | 14.246 | 13.958 | 12.87 | 12.80 | 1.290 |
| 5/8 | 11 | 15.834 | 15.528 | 14.33 | 14.26 | 1.386 |
| 3/4 | 10 | 19.004 | 18.677 | 17.34 | 17.27 | 1.535 |
| 7/8 | 9 | 22.176 | 21.824 | 20.34 | 20.26 | 1.650 |
| 1 | 8 | 25.349 | 24.969 | 23.28 | 23.20 | 1.919 |
| 1 1/8 | 7 | 28.519 | 28.103 | 26.16 | 26.07 | 2.196 |
| 1 1/4 | 7 | 31.694 | 31.278 | 29.33 | 29.24 | 2.210 |
| 1 3/8 | 7 | 34.864 | 34.002 | 32.12 | 32.02 | 2.563 |

| UNF MACHINE SCREW 2A Q(60°) 美 國 細 牙 規 格 | | | | | | |
|--|------------|--------------|--------------|--------------|--------------|------------------|
| 規格 SIZE | 牙數 P(T) | 外徑(D) | | 螺造徑(d) | | (B) 牙山 高度數 |
| | | 最大 (MAX.) | 最小 (MIN.) | 最大 (MAX.) | 最小 (MIN.) | |
| NO. 2 | 64 | 2.169 | 2.073 | 1.90 | 1.87 | 0.235 |
| NO. 3 | 56 | 2.496 | 2.393 | 2.19 | 2.16 | 0.268 |
| NO. 4 | 48 | 2.827 | 2.713 | 2.46 | 2.43 | 0.310 |
| NO. 5 | 44 | 3.157 | 3.036 | 2.76 | 2.73 | 0.351 |
| NO. 6 | 40 | 3.484 | 3.356 | 3.05 | 3.02 | 0.380 |
| NO. 8 | 36 | 4.145 | 4.006 | 3.66 | 3.63 | 0.430 |
| NO. 10 | 32 | 4.803 | 4.651 | 4.26 | 4.22 | 0.478 |
| NO. 12 | 28 | 5.461 | 5.296 | 4.84 | 4.80 | 0.550 |
| 1/4 | 28 | 6.324 | 6.160 | 5.72 | 5.68 | 0.550 |
| 5/16 | 24 | 7.909 | 7.727 | 7.20 | 7.16 | 0.640 |
| 3/8 | 24 | 9.497 | 9.315 | 8.76 | 8.74 | 0.640 |
| 7/16 | 20 | 11.079 | 10.874 | 10.23 | 10.18 | 0.760 |
| 1/2 | 20 | 12.666 | 12.462 | 11.82 | 11.76 | 0.760 |
| 9/16 | 18 | 14.251 | 14.031 | 13.31 | 13.25 | 0.849 |
| 5/8 | 18 | 15.839 | 15.619 | 14.89 | 14.83 | 0.849 |
| 3/4 | 16 | 19.011 | 18.774 | 17.95 | 17.89 | 0.947 |
| 7/8 | 14 | 22.184 | 21.923 | 20.98 | 20.91 | 1.086 |
| 1 | 12 | 25.254 | 25.065 | 23.95 | 23.87 | 1.290 |
| 1 1/8 | 12 | 28.529 | 28.240 | 27.12 | 27.05 | 1.290 |
| 1 1/4 | 12 | 31.704 | 31.415 | 30.29 | 30.21 | 1.290 |
| 1 3/8 | 12 | 34.876 | 34.588 | 33.46 | 33.38 | 1.290 |
| 1 1/2 | 12 | 38.051 | 37.763 | 36.63 | 36.55 | 1.290 |



木螺絲規格表 WOOD SCREW SIZE

| WOOD SCREW M/M TYPE M/M 米厘木螺絲規格 | | | | | |
|------------------------------------|------------|--------------|--------------|--------------|--------------|
| 規格 SIZE | 牙距 P(T) | 外徑(D) | | 螺造徑(d) | |
| | | 最大 (MAX.) | 最小 (MIN.) | 最大 (MAX.) | 最小 (MIN.) |
| 1.6 | 0.8 | 1.65 | 1.55 | 1.20 | 1.15 |
| 1.8 | 0.9 | 1.85 | 1.75 | 1.40 | 1.35 |
| 2.1 | 1.0 | 2.17 | 2.03 | 1.60 | 1.55 |
| 2.4 | 1.1 | 2.47 | 2.33 | 1.90 | 1.85 |
| 2.7 | 1.2 | 2.77 | 2.63 | 2.10 | 2.05 |
| 3.1 | 1.3 | 3.17 | 3.03 | 2.45 | 2.40 |
| 3.5 | 1.4 | 3.60 | 3.40 | 2.85 | 2.75 |
| 3.8 | 1.6 | 3.90 | 3.70 | 3.05 | 3.00 |
| 4.1 | 1.8 | 4.20 | 4.00 | 3.25 | 3.20 |
| 4.5 | 2.0 | 4.60 | 4.40 | 3.50 | 3.45 |
| 4.8 | 2.1 | 4.92 | 4.68 | 3.75 | 3.70 |
| 5.1 | 2.2 | 5.22 | 4.98 | 4.00 | 3.90 |
| 5.5 | 2.4 | 5.62 | 5.38 | 4.35 | 4.30 |
| 5.8 | 2.6 | 5.92 | 5.68 | 4.50 | 4.45 |
| 6.2 | 2.7 | 6.32 | 6.08 | 4.85 | 4.75 |
| 6.8 | 3.1 | 6.95 | 6.65 | 5.30 | 5.20 |
| 7.5 | 3.3 | 7.65 | 7.35 | 5.80 | 5.70 |
| 8.0 | 3.3 | 8.15 | 7.85 | 6.30 | 6.20 |
| 9.5 | 3.8 | 9.65 | 9.35 | 7.60 | 7.50 |

| DIN WOOD SCREW DIN TYPE 97木螺絲規格表 | | | | | |
|-------------------------------------|------------|--------------|--------------|--------------|--------------|
| 規格 SIZE | 牙距 P(T) | 外徑(D) | | 螺造徑(d) | |
| | | 最大 (MAX.) | 最小 (MIN.) | 最大 (MAX.) | 最小 (MIN.) |
| 1.4 | 0.6 | 1.4 | 1.30 | 1.10 | 1.05 |
| 1.6 | 0.7 | 1.6 | 1.50 | 1.20 | 1.15 |
| 1.7 | 0.8 | 1.7 | 1.60 | 1.30 | 1.25 |
| 2.0 | 0.9 | 2.0 | 1.90 | 1.55 | 1.50 |
| 2.4 | 1.0 | 2.4 | 2.30 | 1.90 | 1.85 |
| 2.7 | 1.2 | 2.7 | 2.60 | 2.15 | 2.10 |
| 3.0 | 1.35 | 3.0 | 2.85 | 2.25 | 2.20 |
| 3.5 | 1.6 | 3.5 | 3.35 | 2.65 | 2.60 |
| 4.0 | 1.8 | 4.0 | 3.85 | 3.05 | 3.00 |
| 4.5 | 2.0 | 4.5 | 4.35 | 3.40 | 3.35 |
| 5.0 | 2.2 | 5.0 | 4.85 | 3.80 | 3.75 |
| 5.5 | 2.4 | 5.5 | 5.35 | 4.20 | 4.15 |
| 6.0 | 2.6 | 6.0 | 5.85 | 4.70 | 4.65 |
| 7.0 | 3.2 | 7.0 | 6.85 | 5.30 | 5.25 |
| 8.0 | 3.5 | 8.0 | 7.85 | 6.20 | 6.15 |
| 9.0 | 4.0 | 9.0 | 8.85 | 6.80 | 6.75 |
| 10.0 | 4.5 | 10.0 | 9.85 | 7.60 | 7.55 |
| 12.0 | 5.0 | 12.0 | 11.65 | 9.30 | 9.25 |
| 16.0 | 6.0 | 16.0 | 15.65 | 13.00 | 12.95 |

THREAD ACCORDING TO DIN7998

| WOOD SCREW ASA TYPE 美國木螺絲規格 | | | | | |
|--------------------------------|------------|--------------|--------------|--------------|--------------|
| 規格 SIZE | 牙數 P(T) | 外徑(D) | | 螺造徑(d) | |
| | | 最大 (MAX.) | 最小 (MIN.) | 最大 (MAX.) | 最小 (MIN.) |
| NO: 0 | 32 | 1.62 | 1.34 | 1.20 | 1.15 |
| NO: 1 | 28 | 1.95 | 1.67 | 1.50 | 1.45 |
| NO: 2 | 26 | 2.28 | 2.00 | 1.70 | 1.65 |
| NO: 3 | 24 | 2.61 | 2.33 | 2.00 | 1.95 |
| NO: 4 | 22 | 2.94 | 2.66 | 2.25 | 2.20 |
| NO: 5 | 20 | 3.27 | 2.99 | 2.55 | 2.50 |
| NO: 6 | 18 | 3.60 | 3.32 | 2.80 | 2.75 |
| NO: 7 | 16 | 3.93 | 3.65 | 3.10 | 3.05 |
| NO: 8 | 15 | 4.26 | 3.98 | 3.35 | 3.30 |
| NO: 9 | 14 | 4.59 | 4.31 | 3.45 | 3.40 |
| NO:10 | 13 | 4.92 | 4.64 | 3.85 | 3.80 |
| NO:12 | 11 | 5.58 | 5.30 | 4.35 | 4.30 |
| NO:14 | 10 | 6.24 | 5.97 | 4.85 | 4.80 |
| NO:16 | 9 | 6.90 | 6.63 | 5.20 | 5.15 |
| NO:18 | 8 | 7.57 | 7.29 | 5.75 | 5.70 |
| NO:20 | 8 | 8.22 | 7.59 | 6.40 | 6.35 |
| NO:24 | 7 | 9.55 | 9.27 | 7.50 | 7.40 |

| SQUARE AND HEX LAG SCREWS 美國木螺絲規格 | | | | | |
|--------------------------------------|------------|--------------|--------------|--------------|--------------|
| 規格 SIZE | 牙數 P(T) | 外徑(D) | | 螺造徑(d) | |
| | | 最大 (MAX.) | 最小 (MIN.) | 最大 (MAX.) | 最小 (MIN.) |
| NO: 10 | 11 | 5.05 | 4.52 | 3.75 | 3.70 |
| 1/4 | 10 | 6.60 | 6.02 | 5.05 | 4.95 |
| 5/16 | 9 | 8.23 | 7.57 | 6.35 | 6.25 |
| 3/8 | 7 | 9.85 | 9.15 | 7.60 | 7.50 |
| 7/16 | 7 | 11.48 | 10.70 | 9.20 | 9.10 |
| 1/2 | 6 | 13.08 | 12.25 | 10.40 | 10.30 |
| 5/8 | 5 | 16.30 | 15.37 | 13.20 | 13.10 |
| 3/4 | 4 1/2 | 19.50 | 18.51 | 16.10 | 16.00 |

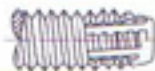

鐵板螺絲規格表 TAPPING SCREW SIZE









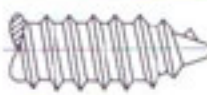
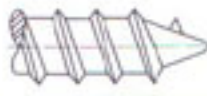
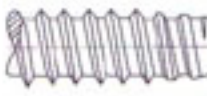

| TAPPING SCREW ASA TYPE A 美國規格鐵板螺絲 | | | | | |
|--------------------------------------|------------|--------------|--------------|--------------|--------------|
| 規格 SIZE | 牙數 P(T) | 外徑(D) | | 螺造徑(d) | |
| | | 最大 (MAX.) | 最小 (MIN.) | 最大 (MAX.) | 最小 (MIN.) |
| NO: 0 | 40 | 1.52 | 1.44 | 1.20 | 1.15 |
| NO: 1 | 32 | 1.90 | 1.82 | 1.50 | 1.45 |
| NO: 2 | 32 | 2.23 | 2.13 | 1.80 | 1.75 |
| NO: 3 | 28 | 2.56 | 2.46 | 2.10 | 2.05 |
| NO: 4 | 24 | 2.89 | 2.79 | 2.30 | 2.25 |
| NO: 5 | 20 | 3.30 | 3.20 | 2.65 | 2.60 |
| NO: 6 | 18 | 3.58 | 3.45 | 2.80 | 2.75 |
| NO: 7 | 16 | 4.01 | 3.86 | 3.15 | 3.10 |
| NO: 8 | 15 | 4.26 | 4.11 | 3.35 | 3.30 |
| NO: 9 | 14 | 4.55 | 4.40 | 3.50 | 3.45 |
| NO:10 | 12 | 4.92 | 4.77 | 3.75 | 3.70 |
| NO:12 | 11 | 5.60 | 5.46 | 4.40 | 4.35 |
| NO:14 | 10 | 6.45 | 6.29 | 5.10 | 5.05 |
| NO:16 | 10 | 7.11 | 6.96 | 5.70 | 5.65 |
| NO:18 | 9 | 7.77 | 7.62 | 6.10 | 6.05 |

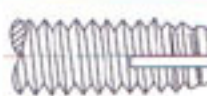
| TAPPING SCREW ASA TYPE AB.(B) 美國規格鐵板螺絲 | | | | | |
|---|------------|--------------|--------------|--------------|--------------|
| 規格 SIZE | 牙數 P(T) | 外徑(D) | | 螺造徑(d) | |
| | | 最大 (MAX.) | 最小 (MIN.) | 最大 (MAX.) | 最小 (MIN.) |
| NO: 0 | 48 | 1.52 | 1.44 | 1.25 | 1.20 |
| NO: 1 | 42 | 1.90 | 1.82 | 1.60 | 1.55 |
| NO: 2 | 32 | 2.23 | 2.13 | 1.80 | 1.75 |
| NO: 3 | 28 | 2.56 | 2.46 | 2.05 | 2.00 |
| NO: 4 | 24 | 2.89 | 2.79 | 2.30 | 2.25 |
| NO: 5 | 20 | 3.30 | 3.20 | 2.60 | 2.55 |
| NO: 6 | 20 | 3.53 | 3.43 | 2.85 | 2.80 |
| NO: 7 | 19 | 3.91 | 3.78 | 3.15 | 3.10 |
| NO: 8 | 18 | 4.21 | 4.09 | 3.40 | 3.35 |
| NO:10 | 16 | 4.80 | 4.65 | 3.90 | 3.85 |
| NO:12 | 14 | 5.46 | 5.31 | 4.40 | 4.35 |
| 1/4 | 14 | 6.25 | 6.10 | 5.20 | 5.15 |
| 5/16 | 12 | 8.00 | 7.82 | 6.75 | 6.70 |

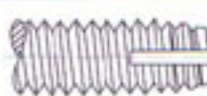
| TAPPING SCREW M/M TYPE A 米厘規格鐵板螺絲 | | | | | |
|--------------------------------------|------------|--------------|--------------|--------------|--------------|
| 規格 SIZE | 牙數 P(T) | 外徑(D) | | 螺造徑(d) | |
| | | 最大 (MAX.) | 最小 (MIN.) | 最大 (MAX.) | 最小 (MIN.) |
| M2 | 32 | 2.10 | 2.00 | 1.75 | 1.70 |
| M2.3 | 32 | 2.40 | 2.30 | 2.00 | 1.95 |
| M2.6 | 28 | 2.70 | 2.60 | 2.20 | 2.15 |
| M3 | 24 | 3.10 | 3.00 | 2.45 | 2.40 |
| M3.5 | 18 | 3.65 | 3.50 | 2.85 | 2.80 |
| M4 | 16 | 4.15 | 4.00 | 3.30 | 3.25 |
| M4.5 | 14 | 4.65 | 4.50 | 3.60 | 3.55 |
| M5 | 12 | 5.20 | 5.00 | 3.95 | 3.90 |
| M6 | 10 | 6.20 | 6.00 | 4.80 | 4.75 |
| M8 | 9 | 8.20 | 8.00 | 6.45 | 6.40 |

| TAPPING SCREW M/M TYPE AB.(B) 米厘規格鐵板螺絲 | | | | | |
|---|------------|--------------|--------------|--------------|--------------|
| 規格 SIZE | 牙數 P(T) | 外徑(D) | | 螺造徑(d) | |
| | | 最大 (MAX.) | 最小 (MIN.) | 最大 (MAX.) | 最小 (MIN.) |
| M2 | 40 | 2.0 | 1.90 | 1.70 | 1.65 |
| M2.3 | 32 | 2.3 | 2.20 | 1.90 | 1.85 |
| M2.6 | 28 | 2.6 | 2.50 | 2.15 | 2.10 |
| M3 | 24 | 3.0 | 2.90 | 2.45 | 2.40 |
| M3.5 | 20 | 3.5 | 3.40 | 2.85 | 2.80 |
| M4 | 18 | 4.0 | 3.85 | 3.30 | 3.25 |
| M4.5 | 16 | 4.5 | 4.35 | 3.60 | 3.55 |
| M5 | 16 | 5.0 | 4.85 | 4.10 | 4.05 |
| M6 | 14 | 6.0 | 5.85 | 5.05 | 5.00 |
| M8 | 12 | 8.0 | 7.85 | 6.80 | 6.75 |



| TYPE | ANSI |
|---|------|
|  | AB |
|  | A |
|  | B |
|  | BP |
|  | C |
|  | D |
|  | F |
|  | G |
|  | T |
|  | BF |
|  | BT |
|  | U |
|  | 三角牙 |

| TAPPING SCREW W. T. TYPE A 韋氏規格鐵板螺絲 | | | | | |
|--|------------|--------------|--------------|--------------|--------------|
| 規格 SIZE | 牙數 T(P) | 外徑(D) | | 螺造徑(d) | |
| | | 最大 (MAX.) | 最小 (MIN.) | 最大 (MAX.) | 最小 (MIN.) |
| 3/32" | 32 | 2.48 | 2.38 | 1.85 | 1.8 |
| 1/8" | 24 | 3.27 | 3.17 | 2.60 | 2.55 |
| 5/32" | 16 | 4.07 | 3.97 | 3.20 | 3.15 |
| 3/16" | 12 | 4.86 | 4.76 | 3.75 | 3.7 |
| 1/4" | 10 | 6.45 | 6.35 | 5.2 | 5.15 |
| 5/16" | 9 | 8.0 | 7.9 | 6.35 | 6.3 |
| 3/8" | 7 | 9.63 | 9.53 | 7.65 | 7.6 |
| 1/2" | 6 | 12.8 | 12.7 | 10.45 | 10.4 |

| DIN TAPPING SCREW DIN TYPE 7970 鐵板螺絲規格表 | | | | | |
|--|------------|--------------|--------------|--------------|--------------|
| 規格 SIZE | 牙距 T(P) | 外徑(D) | | 螺造徑(d) | |
| | | 最大 (MAX.) | 最小 (MIN.) | 最大 (MAX.) | 最小 (MIN.) |
| 2.2 | 0.79 | 2.24 | 2.13 | 1.80 | 1.75 |
| 2.9 | 1.06 | 2.90 | 2.79 | 2.30 | 2.25 |
| 3.5 | 1.27 | 3.53 | 3.43 | 2.80 | 2.75 |
| 3.9 | 1.34 | 3.91 | 3.78 | 3.15 | 3.10 |
| 4.2 | 1.41 | 4.22 | 4.08 | 3.40 | 3.35 |
| 4.8 | 1.59 | 4.80 | 4.65 | 3.85 | 3.80 |
| 5.5 | 1.81 | 5.46 | 5.31 | 4.40 | 4.35 |
| 6.3 | 1.81 | 6.25 | 6.10 | 5.15 | 5.10 |
| 8.0 | 2.12 | 8.00 | 7.82 | 6.75 | 6.70 |



三角牙螺絲 S型(S TYPE) TAPTITE SCREW

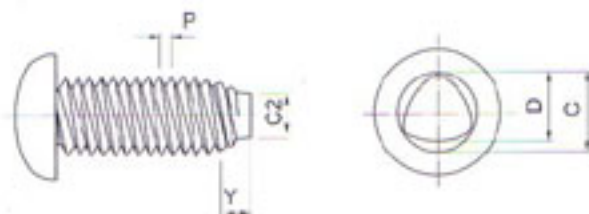

螺絲尺寸

| 規 格 SIZE | 螺絲牙 英寸 PITCH | 螺絲徑 SCREW DIA | | | | 先端部(螺杆) | | 尾部長度 | | 螺造徑 | |
|----------------|--------------------|---------------|--------------|--------------|--------------|-------------------|--------------|--------------|--------------|----------------|----------------|
| | | C mm | | D mm | | C ₂ mm | | Y mm | | C ₁ | D ₁ |
| | | 最大 (MAX.) | 最小 (MIN.) | 最大 (MAX.) | 最小 (MIN.) | 最大 (MAX.) | 最小 (MIN.) | 最大 (MAX.) | 最小 (MIN.) | | |
| 2 | 0.4 | 2.04 | 1.96 | 1.96 | 1.88 | 1.58 | 1.44 | 1.8 | 1.4 | 1.75 | 1.67 |
| 2.3 | 0.4 | 2.34 | 2.26 | 2.26 | 2.18 | 1.82 | 1.68 | 1.8 | 1.4 | 2.04 | 1.96 |
| 2.5 | 0.45 | 2.55 | 2.47 | 2.46 | 2.38 | 1.96 | 1.79 | 2.1 | 1.5 | 2.22 | 2.13 |
| 2.6 | 0.45 | 2.65 | 2.57 | 2.56 | 2.48 | 2.05 | 1.88 | 2.1 | 1.5 | 2.32 | 2.24 |
| 3 | 0.5 | 3.05 | 2.97 | 2.95 | 2.87 | 2.44 | 2.24 | 2.3 | 1.7 | 2.69 | 2.59 |
| 3.5 | 0.6 | 3.56 | 3.48 | 3.44 | 3.36 | 2.83 | 2.63 | 2.7 | 2.1 | 3.13 | 3.01 |
| 4 | 0.7 | 4.07 | 3.99 | 3.93 | 3.85 | 3.27 | 3.07 | 3.2 | 2.4 | 3.56 | 3.42 |
| 5 | 0.8 | 5.08 | 5.00 | 4.92 | 4.84 | 4.17 | 3.87 | 3.6 | 2.8 | 4.52 | 4.36 |

三角牙螺絲 C型(C TYPE) TAPTITE SCREW

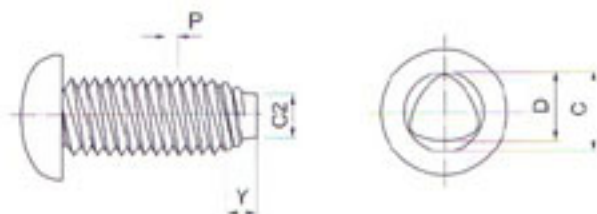

螺絲尺寸

| 規 格 SIZE | 螺絲牙 英寸 PITCH | 螺絲徑 SCREW DIA | | | | 先端部(螺杆) | | 尾部長度 | | 螺造徑 | |
|----------------|--------------------|---------------|--------------|--------------|--------------|-------------------|--------------|--------------|--------------|----------------|----------------|
| | | C mm | | D mm | | C ₂ mm | | Y mm | | C ₁ | D ₁ |
| | | 最大 (MAX.) | 最小 (MIN.) | 最大 (MAX.) | 最小 (MIN.) | 最大 (MAX.) | 最小 (MIN.) | 最大 (MAX.) | 最小 (MIN.) | | |
| 2 | 0.4 | 1.98 | 1.89 | 1.90 | 1.81 | 1.52 | 1.36 | 1.8 | 1.4 | 1.68 | 1.60 |
| 2.3 | 0.4 | 2.28 | 2.19 | 2.20 | 2.11 | 1.76 | 1.62 | 1.8 | 1.4 | 1.98 | 1.90 |
| 2.5 | 0.45 | 2.48 | 2.38 | 2.39 | 2.29 | 1.88 | 1.71 | 2.1 | 1.5 | 2.14 | 2.05 |
| 2.6 | 0.45 | 2.58 | 2.48 | 2.49 | 2.39 | 1.98 | 1.81 | 2.1 | 1.5 | 2.24 | 2.15 |
| 3 | 0.5 | 2.98 | 2.87 | 2.88 | 2.77 | 2.37 | 2.17 | 2.3 | 1.7 | 2.61 | 2.51 |
| 3.5 | 0.6 | 3.47 | 3.36 | 3.35 | 3.24 | 2.76 | 2.56 | 2.7 | 2.1 | 3.03 | 2.91 |
| 4 | 0.7 | 3.97 | 3.84 | 3.83 | 3.70 | 3.17 | 2.91 | 3.2 | 2.4 | 3.46 | 3.32 |
| 5 | 0.8 | 4.97 | 4.84 | 4.81 | 4.68 | 4.06 | 3.76 | 3.6 | 2.6 | 4.38 | 4.22 |

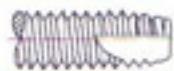
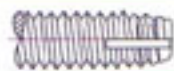

三角牙螺絲 B型(B TYPE) TAPTITE SCREW

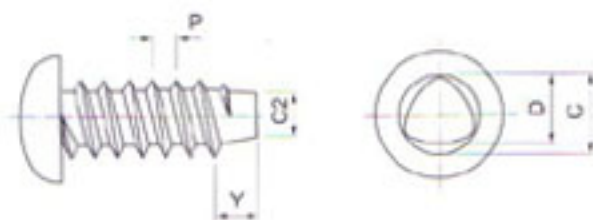

螺絲尺寸

| 規 格 SIZE | 螺絲牙 距 PITCH | 螺絲徑 SCREW DIA | | | | 先端部(螺杆) | | 尾部長度 Y mm | | 製造徑 | |
|----------------|-------------------|---------------|--------------|--------------|--------------|-------------------|--------------|--------------|--------------|----------------|----------------|
| | | C mm | | D mm | | C ₂ mm | | 最大 (MAX.) | 最小 (MIN.) | C ₁ | D ₁ |
| | | 最大 (MAX.) | 最小 (MIN.) | 最大 (MAX.) | 最小 (MIN.) | 最大 (MAX.) | 最小 (MIN.) | | | | |
| 2 | 40 | 2.04 | 1.96 | 1.96 | 1.88 | 1.46 | 1.26 | 1.6 | 1.2 | 1.67 | 1.59 |
| 2.3 | 32 | 2.34 | 2.26 | 2.26 | 2.18 | 1.76 | 1.56 | 2.0 | 1.5 | 1.89 | 1.81 |
| 2.6 | 28 | 2.64 | 2.56 | 2.55 | 2.47 | 1.94 | 1.74 | 2.3 | 1.8 | 2.16 | 2.07 |
| 3 | 24 | 3.05 | 2.95 | 2.95 | 2.85 | 2.25 | 2.05 | 2.7 | 2.1 | 2.47 | 2.37 |
| 3.5 | 20 | 3.55 | 3.45 | 3.46 | 3.34 | 2.65 | 2.45 | 3.2 | 2.5 | 2.90 | 2.78 |
| 4 | 18 | 4.05 | 3.95 | 3.91 | 3.81 | 3.00 | 2.80 | 3.6 | 2.8 | 3.28 | 3.14 |
| 5 | 16 | 5.06 | 4.94 | 4.90 | 4.78 | 3.74 | 3.44 | 4.0 | 3.1 | 4.16 | 4.00 |

三角牙螺絲 P型(P TYPE) TAPTITE SCREW

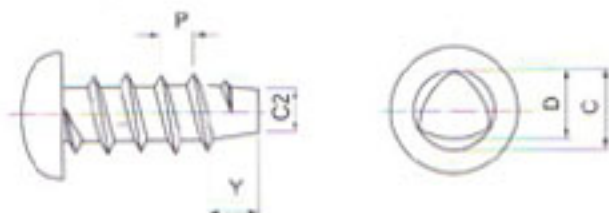

螺絲尺寸

| 規 格 SIZE | 螺絲牙 距 PITCH | 螺絲徑 SCREW DIA | | | | 先端部(螺杆) | | 尾部長度 Y mm | | 製造徑 | |
|----------------|-------------------|---------------|--------------|--------------|--------------|-------------------|--------------|--------------|--------------|----------------|----------------|
| | | C mm | | D mm | | C ₂ mm | | 最大 (MAX.) | 最小 (MIN.) | C ₁ | D ₁ |
| | | 最大 (MAX.) | 最小 (MIN.) | 最大 (MAX.) | 最小 (MIN.) | 最大 (MAX.) | 最小 (MIN.) | | | | |
| 2.0 | 32 | 2.12 | 2.02 | 2.04 | 1.94 | 1.54 | 1.34 | 2.0 | 1.6 | 1.60 | 1.52 |
| 2.3 | 28 | 2.43 | 2.33 | 2.35 | 2.25 | 1.84 | 1.64 | 2.3 | 1.8 | 1.87 | 1.79 |
| 2.5 | 24 | 2.63 | 2.53 | 2.54 | 2.44 | 1.94 | 1.74 | 2.5 | 2.0 | 1.99 | 1.90 |
| 2.6 | 24 | 2.73 | 2.63 | 2.64 | 2.54 | 2.04 | 1.84 | 2.5 | 2.0 | 2.12 | 2.04 |
| 3.0 | 20 | 3.15 | 3.03 | 3.05 | 2.93 | 2.35 | 2.15 | 3.3 | 2.6 | 2.43 | 2.33 |
| 3.5 | 18 | 3.66 | 3.54 | 3.57 | 3.45 | 2.70 | 2.50 | 3.5 | 2.8 | 2.67 | 2.75 |
| 4.0 | 16 | 4.16 | 4.04 | 4.02 | 3.90 | 3.10 | 2.90 | 4.0 | 3.2 | 3.23 | 3.10 |
| 5.0 | 14 | 5.19 | 5.05 | 5.03 | 4.89 | 3.76 | 3.45 | 4.5 | 3.6 | 4.03 | 3.87 |



薄板螺絲、牆板螺絲規格表 CHIPBOARD & DRYWALL SCREW SIZE

| CHIPBOARD SCREWS 40° 規格表 | | | | |
|-----------------------------|---------|--------------|--------------|------|
| 規格 SIZE | 牙距 P | 外徑(D) | | 螺造徑 |
| | | 最大 (MAX.) | 最小 (MIN.) | |
| 3 | 1.35 | 3.00 | 2.80 | 2.15 |
| 3.5 | 1.60 | 3.50 | 3.30 | 2.47 |
| 4 | 1.80 | 4.00 | 3.75 | 2.80 |
| 4.5 | 2.00 | 4.50 | 4.25 | 3.13 |
| 5 | 2.20 | 5.00 | 4.70 | 3.47 |
| 6 | 2.60 | 6.00 | 5.70 | 4.20 |

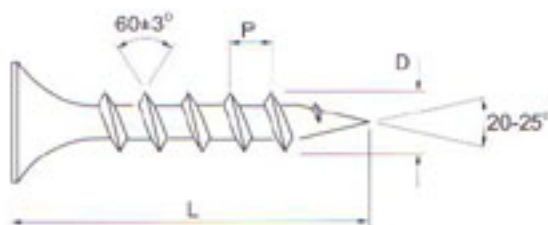
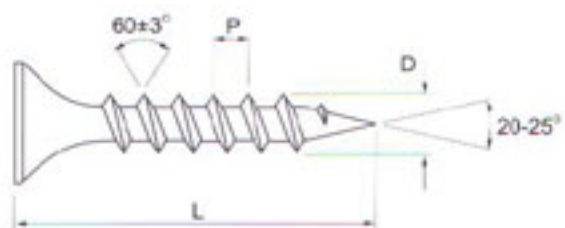
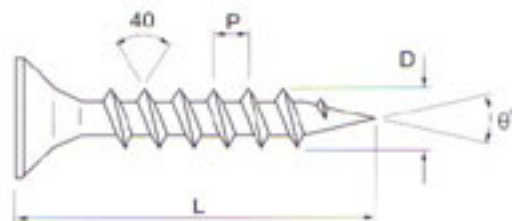

| DRY WALL SCREWS | | | | |
|-----------------|---------|--------------|--------------|------|
| 規格 SIZE | 牙數 P | 外徑(D) | | 螺造徑 |
| | | 最大 (MAX.) | 最小 (MIN.) | |
| # 6 | 17 | 3.60 | 3.40 | 2.70 |
| # 7 | 16 | 4.00 | 3.75 | 3.00 |
| # 8 | 15 | 4.30 | 4.05 | 3.20 |
| # 10 | 12 | 4.95 | 4.70 | 3.70 |

| DRY WALL SCREWS | | | | |
|-----------------|---------|--------------|--------------|------|
| 規格 SIZE | 牙數 P | 外徑(D) | | 螺造徑 |
| | | 最大 (MAX.) | 最小 (MIN.) | |
| # 6 | 9 | 3.90 | 3.65 | 2.65 |
| # 7 | 9 | 4.20 | 3.90 | 2.90 |
| # 8 | 9 | 4.60 | 4.30 | 3.20 |
| # 10 | 8 | 5.30 | 4.90 | 3.70 |



鑽尾螺絲模具(DRILL POINT SCREW DIES)

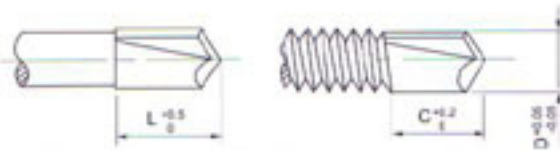
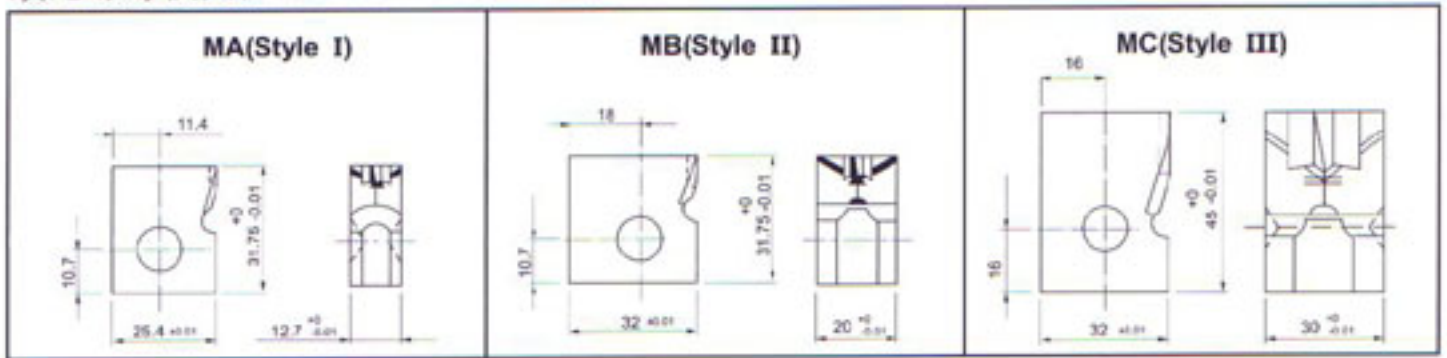

| NO 1 DRILL POINT DIES | | | | | |
|-----------------------|-----------------|------------------|------------------|------------------------|---------------------|
| DP DIE CODE | DRILL DIA. (D0) | FLUTE LENGTH (L) | DRILL LENGTH (C) | MAX MATERIAL THICKNESS | DP DIE STYLE |
| L1-22 | 2.2 | 2.7 | 1.7 | 1.0 | STYLE I STYLE II |
| -23 | 2.3 | | | | |
| -28 | 2.8 | | | | |
| -29 | 2.9 | 3.4 | 2.4 | 1.5 | |
| -30 | 3.0 | | | | |
| -31 | 3.1 | | | | |
| L1-32 | 3.2 | 4.2 | 3.2 | 2.1 | |
| -33 | 3.3 | | | | |
| -34 | 3.4 | | | | |
| -35 | 3.5 | 5.0 | 4.0 | 2.8 | |
| -36 | 3.6 | | | | |
| L1-37 | 3.7 | | | | |
| -38 | 3.8 | 6.0 | 5.0 | 3.6 | |
| -39 | 3.9 | | | | |
| -40 | 4.0 | | | | |
| -41 | 4.1 | 7.2 | 6.2 | 4.5 | |
| L1-43 | 4.3 | | | | |
| -45 | 4.5 | | | | |
| -47 | 4.7 | 8.0 | 7.0 | 5.3 | |
| L1-49 | 4.9 | | | | |
| -51 | 5.1 | | | | |
| -53 | 5.3 | 9.0 | 8.0 | 6.3 | |
| -55 | 5.5 | | | | |
| -57 | 5.7 | | | | |

| NO 2 DRILL POINT DIES | | | | | |
|-----------------------|-----------------|------------------|------------------|------------------------|---------------------|
| DP DIE CODE | DRILL DIA. (D0) | FLUTE LENGTH (L) | DRILL LENGTH (C) | MAX MATERIAL THICKNESS | DP DIE STYLE |
| L2-22 | 2.2 | 3.2 | 2.2 | 1.5 | STYLE I STYLE II |
| -23 | 2.3 | | | | |
| L2-27 | 2.7 | | | | |
| -28 | 2.8 | 4.0 | 3.0 | 2.1 | |
| -29 | 2.9 | | | | |
| -30 | 3.0 | | | | |
| -31 | 3.1 | 4.9 | 3.9 | 2.8 | |
| L2-32 | 3.2 | | | | |
| -33 | 3.3 | | | | |
| -34 | 3.4 | 5.8 | 4.8 | 3.6 | |
| -35 | 3.5 | | | | |
| -36 | 3.6 | | | | |
| L2-37 | 3.7 | 6.9 | 5.9 | 4.5 | |
| -38 | 3.8 | | | | |
| -39 | 3.9 | | | | |
| -40 | 4.0 | 8.0 | 7.0 | 5.3 | |
| -41 | 4.1 | | | | |
| L2-43 | 4.3 | | | | |
| -45 | 4.5 | 9.0 | 8.0 | 6.3 | |
| -47 | 4.7 | | | | |
| L2-49 | 4.9 | | | | |
| -51 | 5.1 | 10.0 | 9.0 | 7.3 | |
| -53 | 5.3 | | | | |
| -55 | 5.5 | | | | |
| -57 | 5.7 | | | | |

| NO 3 DRILL POINT DIES | | | | | |
|-----------------------|-----------------|------------------|------------------|------------------------|---------------------|
| DP DIE CODE | DRILL DIA. (D0) | FLUTE LENGTH (L) | DRILL LENGTH (C) | MAX MATERIAL THICKNESS | DP DIE STYLE |
| L3-27 | 2.7 | 4.7 | 3.7 | 2.8 | STYLE I STYLE II |
| -28 | 2.8 | | | | |
| -29 | 2.9 | | | | |
| -30 | 3.0 | 5.7 | 4.7 | 3.6 | |
| -31 | 3.1 | | | | |
| L3-32 | 3.2 | | | | |
| -33 | 3.3 | 6.7 | 5.7 | 4.5 | |
| -34 | 3.4 | | | | |
| -35 | 3.5 | | | | |
| -36 | 3.6 | 7.7 | 6.7 | 5.3 | |
| L3-37 | 3.7 | | | | |
| -38 | 3.8 | | | | |
| -39 | 3.9 | 9.0 | 8.0 | 6.3 | |
| -40 | 4.0 | | | | |
| -41 | 4.1 | | | | |
| L3-43 | 4.3 | 10.0 | 9.0 | 7.3 | |
| -45 | 4.5 | | | | |
| -47 | 4.7 | | | | |
| L3-49 | 4.9 | 11.0 | 10.0 | 8.3 | |
| -51 | 5.1 | | | | |
| -53 | 5.3 | | | | |
| -55 | 5.5 | 12.0 | 11.0 | 9.3 | |
| -57 | 5.7 | | | | |

| NO 4 DRILL POINT DIES | | | | | |
|-----------------------|-----------------|------------------|------------------|------------------------|--------------|
| DP DIE CODE | DRILL DIA. (D0) | FLUTE LENGTH (L) | DRILL LENGTH (C) | MAX MATERIAL THICKNESS | DP DIE STYLE |
| L4-43 | 4.3 | 8.7 | 7.7 | 6.3 | STYLE II |
| -45 | 4.5 | | | | |
| -47 | 4.7 | | | | |
| L4-49 | 4.9 | 11.7 | 10.7 | 9.0 | |
| -51 | 5.1 | | | | |
| -53 | 5.3 | | | | |
| -55 | 5.5 | 12.7 | 11.7 | 9.7 | |
| -57 | 5.7 | | | | |

| NO 5 DRILL POINT DIES | | | | | |
|-----------------------|-----------------|------------------|------------------|------------------------|--------------|
| DP DIE CODE | DRILL DIA. (D0) | FLUTE LENGTH (L) | DRILL LENGTH (C) | MAX MATERIAL THICKNESS | DP DIE STYLE |
| L5-49 | 4.9 | 14.7 | 13.7 | 12.0 | STYLE III |
| -51 | 5.1 | | | | |
| -53 | 5.3 | | | | |
| -55 | 5.5 | 15.7 | 14.7 | 13.0 | |
| -57 | 5.7 | | | | |

| NO 6 DRILL POINT DIES | | | | | |
|-----------------------|-----------------|------------------|------------------|------------------------|--------------|
| DP DIE CODE | DRILL DIA. (D0) | FLUTE LENGTH (L) | DRILL LENGTH (C) | MAX MATERIAL THICKNESS | DP DIE STYLE |
| L6-49 | 4.9 | 17.7 | 16.7 | 15.0 | STYLE III |
| -51 | 5.1 | | | | |
| -53 | 5.3 | | | | |
| -55 | 5.5 | 18.7 | 17.7 | 16.0 | |
| -57 | 5.7 | | | | |

模具例圖(TOOLING DRAWING)

HEX. HEADED PUNCH HOLDER

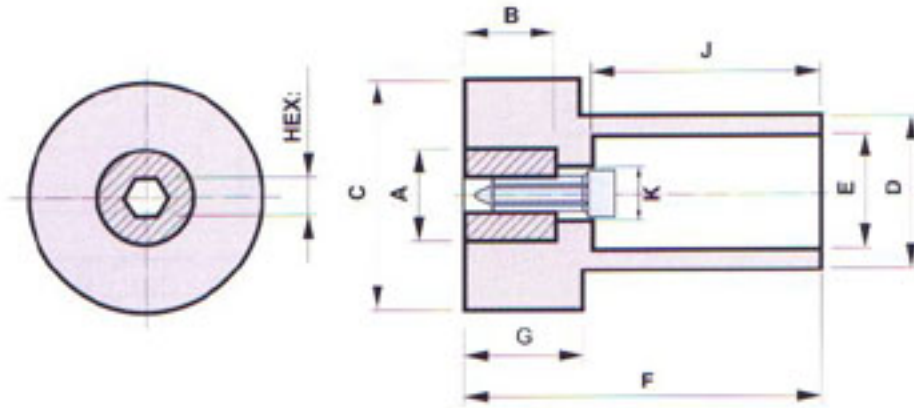

⊕ HEX. PUNCH PIN

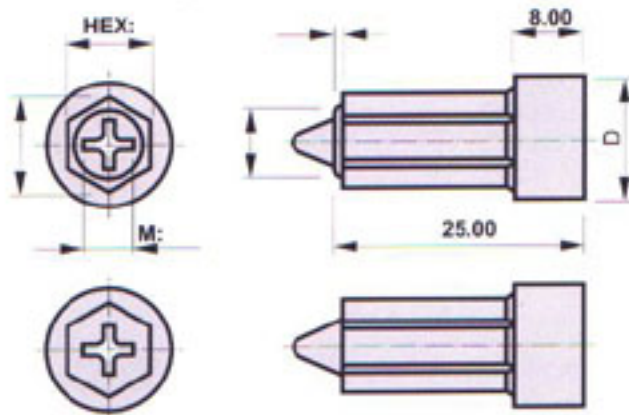

⊖ HEX. PUNCH PIN

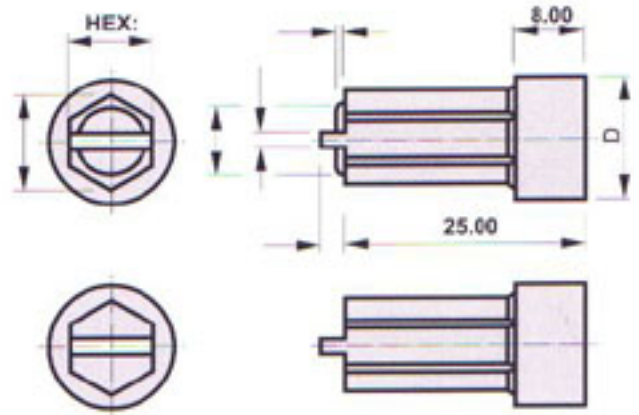

⊕ ⊖ HEX. PUNCH PIN

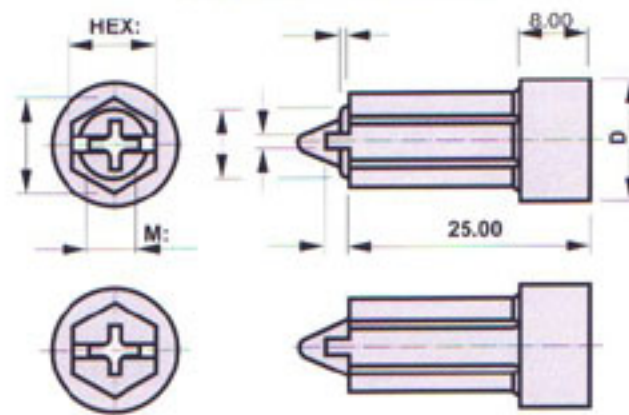

⊕ ROUND. PUNCH PIN

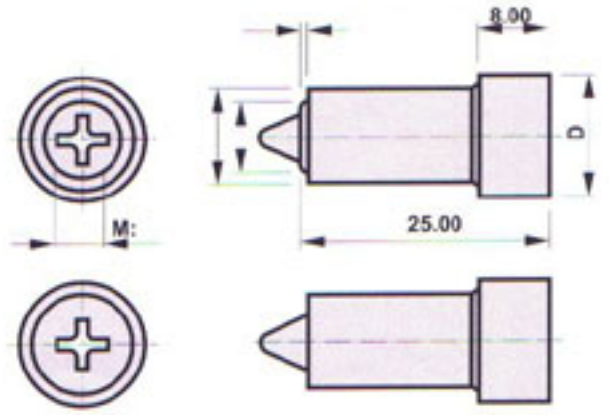

模具例圖(TOOLING DRAWING)

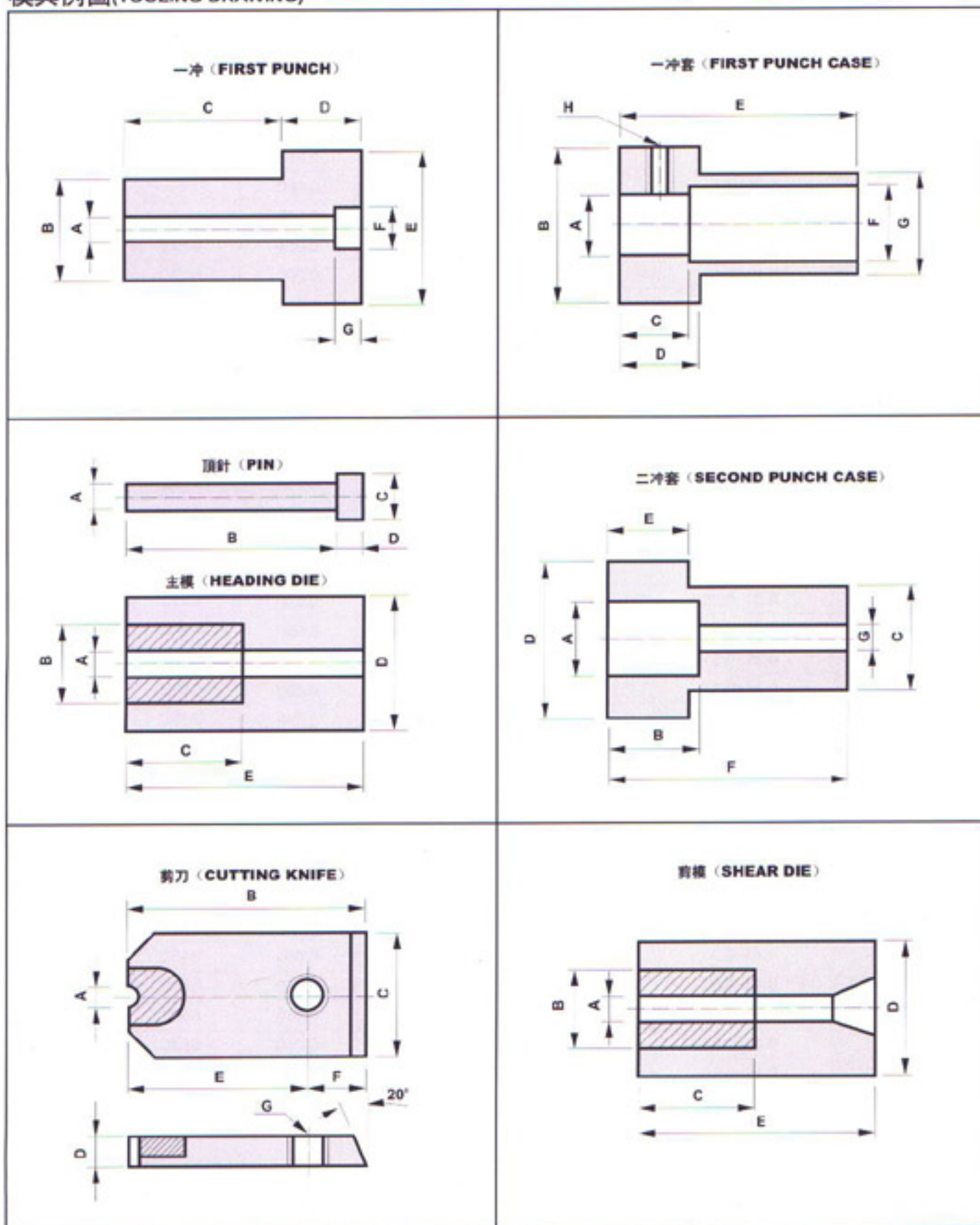

冷打或冷鍛用碳鋼綫材化學成份表

| SAE/AISI 綫材代號 | 化 學 成 份 (%) | | | | 對應 JIS代號 | 對應 DIN代號 |
|------------------|-------------|-----------|--------|--------|-------------|-------------|
| | C | Mn | P (最高) | S (最高) | | |
| 1005 | 0.06MAX. | 0.35MAX. | 0.040 | 0.050 | — | — |
| 1006 | 0.08MAX. | 0.25~0.40 | 0.040 | 0.050 | — | — |
| 1008 | 0.10MAX. | 0.30~0.50 | 0.040 | 0.050 | — | — |
| 1010 | 0.08~0.13 | 0.30~0.60 | 0.040 | 0.050 | S10C | CK10 |
| 1012 | 0.10~0.15 | 0.30~0.60 | 0.040 | 0.050 | S12C | — |
| 1013 | 0.11~0.16 | 0.50~0.80 | 0.040 | 0.050 | — | — |
| 1015 | 0.13~0.18 | 0.30~0.60 | 0.040 | 0.050 | S15C | CK15 |
| 1016 | 0.13~0.18 | 0.60~0.90 | 0.040 | 0.050 | — | — |
| 1017 | 0.15~0.20 | 0.30~0.60 | 0.040 | 0.050 | S17C | — |
| 1018 | 0.15~0.20 | 0.60~0.90 | 0.040 | 0.050 | — | — |
| 1019 | 0.15~0.20 | 0.70~1.00 | 0.040 | 0.050 | — | — |
| 1020 | 0.18~0.23 | 0.30~0.60 | 0.040 | 0.050 | S20C | CK22 |
| 1021 | 0.18~0.23 | 0.60~0.90 | 0.040 | 0.050 | — | — |
| 1022 | 0.18~0.23 | 0.70~1.00 | 0.040 | 0.050 | SMnC420 | 20Mn5 |
| 1023 | 0.20~0.25 | 0.30~0.60 | 0.040 | 0.050 | S22C | CK22 |
| 1025 | 0.22~0.28 | 0.30~0.60 | 0.040 | 0.050 | S25C | CK25 |
| 1026 | 0.22~0.28 | 0.60~0.90 | 0.040 | 0.050 | — | — |
| 1029 | 0.25~0.31 | 0.60~0.90 | 0.040 | 0.050 | S28C | — |
| 1030 | 0.28~0.34 | 0.60~0.90 | 0.040 | 0.050 | S30C | — |
| 1035 | 0.32~0.38 | 0.60~0.90 | 0.040 | 0.050 | S35C | CK35 |
| 1037 | 0.32~0.38 | 0.70~1.00 | 0.040 | 0.050 | S35C | CK35 |
| 1038 | 0.35~0.42 | 0.60~0.90 | 0.040 | 0.050 | S38C | — |
| 1039 | 0.37~0.44 | 0.70~1.00 | 0.040 | 0.050 | S40C | 40Mn4 |
| 1040 | 0.37~0.44 | 0.60~0.90 | 0.040 | 0.050 | S40C | — |
| 1042 | 0.40~0.47 | 0.60~0.90 | 0.040 | 0.050 | S43C | — |
| 1043 | 0.40~0.47 | 0.70~1.00 | 0.040 | 0.050 | S43C | — |
| 1044 | 0.43~0.50 | 0.30~0.60 | 0.040 | 0.050 | — | — |
| 1045 | 0.43~0.50 | 0.60~0.90 | 0.040 | 0.050 | S45C | CK45 |
| 1046 | 0.43~0.50 | 0.70~1.00 | 0.040 | 0.050 | S45C | CK45 |
| 1049 | 0.46~0.53 | 0.60~0.90 | 0.040 | 0.050 | S50C | — |
| 1050 | 0.48~0.55 | 0.60~0.90 | 0.040 | 0.050 | S53C | CK50 |
| 1053 | 0.48~0.55 | 0.70~1.00 | 0.040 | 0.050 | S53C | — |
| 1055 | 0.50~0.60 | 0.60~0.90 | 0.040 | 0.050 | S55C | CK55 |



冷打或冷鍛用碳鋼綫材化學成份表

| JIS 綫材代號 | 化 學 成 份 (%) | | | | | |
|-------------|-------------|-----------|-----------|-------|-------|--------|
| | C | Si | Mn | P(最高) | S(最高) | Al(最低) |
| SWRCH 6R | 0.08最高 | —— | 0.60最高 | 0.040 | 0.040 | —— |
| SWRCH 8R | 0.10最高 | —— | 0.60最高 | 0.040 | 0.040 | —— |
| SWRCH 10R | 0.08-0.13 | —— | 0.30-0.60 | 0.040 | 0.040 | —— |
| SWRCH 12R | 0.10-0.15 | —— | 0.30-0.60 | 0.040 | 0.040 | —— |
| SWRCH 15R | 0.13-0.18 | —— | 0.30-0.60 | 0.040 | 0.040 | —— |
| SWRCH 17R | 0.15-0.20 | —— | 0.30-0.60 | 0.040 | 0.040 | —— |
| SWRCH 6A | 0.08最高 | 0.10最高 | 0.60最高 | 0.030 | 0.035 | 0.02 |
| SWRCH 8A | 0.10最高 | 0.10最高 | 0.60最高 | 0.030 | 0.035 | 0.02 |
| SWRCH 10A | 0.08-0.13 | 0.10最高 | 0.30-0.60 | 0.030 | 0.035 | 0.02 |
| SWRCH 12A | 0.10-0.15 | 0.10最高 | 0.30-0.60 | 0.030 | 0.035 | 0.02 |
| SWRCH 15A | 0.13-0.18 | 0.10最高 | 0.30-0.60 | 0.030 | 0.035 | 0.02 |
| SWRCH 16A | 0.13-0.18 | 0.10最高 | 0.60-0.90 | 0.030 | 0.035 | 0.02 |
| SWRCH 18A | 0.15-0.20 | 0.10最高 | 0.60-0.90 | 0.030 | 0.035 | 0.02 |
| SWRCH 19A | 0.15-0.20 | 0.10最高 | 0.70-1.00 | 0.030 | 0.035 | 0.02 |
| SWRCH 20A | 0.18-0.23 | 0.10最高 | 0.30-0.60 | 0.030 | 0.035 | 0.02 |
| SWRCH 22A | 0.18-0.23 | 0.10最高 | 0.70-1.00 | 0.030 | 0.035 | 0.02 |
| SWRCH 10K | 0.08-0.13 | 0.10-0.35 | 0.30-0.60 | 0.030 | 0.035 | —— |
| SWRCH 12K | 0.10-0.15 | 0.10-0.35 | 0.30-0.60 | 0.030 | 0.035 | —— |
| SWRCH 15K | 0.13-0.18 | 0.10-0.35 | 0.30-0.60 | 0.030 | 0.035 | —— |
| SWRCH 16K | 0.13-0.18 | 0.10-0.35 | 0.60-0.90 | 0.030 | 0.035 | —— |
| SWRCH 17K | 0.15-0.20 | 0.10-0.35 | 0.30-0.60 | 0.030 | 0.035 | —— |
| SWRCH 18K | 0.15-0.20 | 0.10-0.35 | 0.60-0.90 | 0.030 | 0.035 | —— |
| SWRCH 20K | 0.18-0.23 | 0.10-0.35 | 0.30-0.60 | 0.030 | 0.035 | —— |
| SWRCH 22K | 0.18-0.23 | 0.10-0.35 | 0.70-1.00 | 0.030 | 0.035 | —— |
| SWRCH 25K | 0.22-0.28 | 0.10-0.35 | 0.30-0.60 | 0.030 | 0.035 | —— |
| SWRCH 30K | 0.27-0.33 | 0.10-0.35 | 0.60-0.90 | 0.030 | 0.035 | —— |
| SWRCH 35K | 0.32-0.38 | 0.10-0.35 | 0.60-0.90 | 0.030 | 0.035 | —— |
| SWRCH 40K | 0.37-0.43 | 0.10-0.35 | 0.60-0.90 | 0.030 | 0.035 | —— |
| SWRCH 45K | 0.42-0.48 | 0.10-0.35 | 0.60-0.90 | 0.030 | 0.035 | —— |
| SWRCH 50K | 0.47-0.53 | 0.10-0.35 | 0.60-0.90 | 0.030 | 0.035 | —— |



標準不銹鋼綫材化學成份表

| 綫材代號 | 化 學 成 份 (%) | | | | | | | |
|------------------------------|-------------------|--------------------|-------------------|-------------------|--------------------|-------------|-------------|-----------|
| | C _{MAX.} | Mn _{MAX.} | P _{MAX.} | S _{MAX.} | Si _{MAX.} | Cr | Ni | Mo |
| 奧斯田鐵系(AUSTENITIC) | | | | | | | | |
| SUS 301 | 0.15 | 2.00 | 0.045 | 0.030 | 1.00 | 16.00~18.00 | 6.00~8.00 | — |
| SUS 302 | 0.15 | 2.00 | 0.045 | 0.030 | 1.00 | 17.00~19.00 | 8.00~10.00 | — |
| SUS 302B | 0.15 | 2.00 | 0.045 | 0.030 | 2.00~3.00 | 17.00~19.00 | 8.00~10.00 | — |
| SUS 302HQ | 0.08 | 2.00 | 0.040 | 0.030 | 1.00 | 17.00~19.00 | 8.50~10.50 | — |
| SUS 303 | 0.15 | 2.00 | 0.030 | 0.15min | 1.00 | 17.00~19.00 | 8.00~10.00 | 0.60max |
| SUS 304 | 0.08 | 2.00 | 0.045 | 0.030 | 1.00 | 18.00~20.00 | 8.00~12.00 | — |
| SUS 304L | 0.03 | 2.00 | 0.045 | 0.030 | 1.00 | 18.00~20.00 | 8.00~12.00 | — |
| SUS 305 | 0.12 | 2.00 | 0.045 | 0.030 | 1.00 | 17.00~19.00 | 10.00~13.00 | — |
| SUS 305J1 | 0.08 | 2.00 | 0.040 | 0.030 | 1.00 | 16.50~19.00 | 11.00~13.50 | — |
| SUS 310 | 0.25 | 2.00 | 0.045 | 0.030 | 1.50 | 24.00~26.00 | 19.00~22.00 | — |
| SUS 310S | 0.08 | 2.00 | 0.045 | 0.030 | 1.50 | 24.00~26.00 | 19.00~22.00 | — |
| SUS 314 | 0.25 | 2.00 | 0.045 | 0.030 | 1.50~3.00 | 23.00~26.00 | 19.00~22.00 | — |
| SUS 316 | 0.08 | 2.00 | 0.045 | 0.030 | 1.00 | 16.00~18.00 | 10.00~14.00 | 2.00~3.00 |
| SUS 316L | 0.03 | 2.00 | 0.045 | 0.030 | 1.00 | 16.00~18.00 | 10.00~14.00 | 2.00~3.00 |
| SUS 384 | 0.08 | 2.00 | 0.045 | 0.030 | 1.00 | 15.00~17.00 | 17.00~19.00 | — |
| SUS 385 | 0.08 | 2.00 | 0.045 | 0.030 | 1.00 | 11.50~13.50 | 14.00~16.00 | — |
| 肥粒鐵系 (FERRITIC) | | | | | | | | |
| SUS 405 | 0.08 | 1.00 | 0.040 | 0.030 | 1.00 | 11.50~14.50 | — | — |
| SUS 430 | 0.12 | 1.00 | 0.040 | 0.030 | 1.00 | 14.00~18.00 | * | — |
| SUS 430F | 0.12 | 1.25 | 0.060 | 0.15MIN | 1.00 | 14.00~18.00 | — | 0.60max |
| SUS 434 | 0.12 | 1.25 | 0.040 | 0.030 | 1.00 | 16.00~18.00 | * | — |
| SUS 446 | 0.20 | 1.50 | 0.040 | 0.030 | 1.00 | 23.00~27.00 | — | — |
| 麻田散鐵系 (MARTENSITIC) | | | | | | | | |
| SUS 403 | 0.15 | 1.00 | 0.040 | 0.030 | 0.50 | 11.50~13.00 | — | — |
| SUS 410 | 0.15 | 1.00 | 0.040 | 0.030 | 1.00 | 11.50~13.50 | * | — |
| SUS 416 | 0.15 | 1.25 | 0.060 | 0.15min | 1.00 | 12.00~14.00 | — | 0.60max |
| SUS 431 | 0.20 | 1.00 | 0.040 | 0.030 | 1.00 | 15.00~17.00 | 1.25~2.50 | — |
| SUS 440 | 0.95~1.20 | 1.00 | 0.040 | 0.030 | 1.00 | 16.00~18.00 | * | ** |

注：1.代號后附加字母的意思：

L：表示低碳級，碳含量在0.035%以下。

S：表示碳含量低在0.08%以下。

F：表示易切削。

B：表示其矽含量為2.0~3.0%

2.SUS 305J1：冷鍛壓造性比SUS305好，用于壓造比大的盤頭、平頭螺絲及要求牙峰強度和扭力的鐵板螺絲。

3.SUS 302HQ：成份18%鉻~8%鎳加添3%銅，用于頭型比例大、异形等壓造形狀困難的螺絲（如大扁頭螺絲）



PVD 鍍鈦鍍膜特性表

| 項目 \ 鍍膜 | TiN 氮化鈦 | TiCN 碳氮化鈦 | TiAlN 氮化鋁鈦 | CrN 氮化鉻 | WC/C 碳化鎢碳膜 |
|---------------------------------|------------------|------------------|--------------------|---------------|---------------|
| Hardness 微硬度 | HV2000 | HV3000 | HV 3000 ~3500 | HV1800 | HV1400 |
| Friction 摩擦系數 | 0.4 | 0.3~0.4 | 0.4 | 0.5 | 0.1 |
| Coating Thickness 膜厚 | 2~4um | 2~4um | 2~5um | 3~6um | 1~4um |
| COLOR 顏色 | GOLDEN 金黃色 | GRAY 灰色 | DARK PURPLE 暗紫色 | SLIVER 銀白色 | BLACK 黑色 |
| Operation Temperature 最高工作溫度 | 550°C | 400°C | 850°C~1000°C | 700°C | 300°C |
| Coating Temperature 處理溫度 | PVD 400~450°C | PVD 400~450°C | PVD 400~450°C | PVD 400°C | PVD 250°C |

